

PARTS LIST

Attachment Kit P/N 08B15-TM8-100

XM tuner bracket A

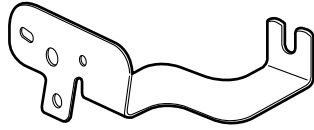

XM tuner bracket B

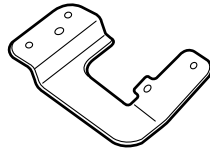

Bus cable

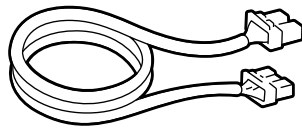

Clip



6 x 16 mm Washer-bolt

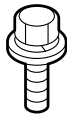

6 mm Washer-nut



4 Washer-screws, 5 x 8 mm



6 Wire ties

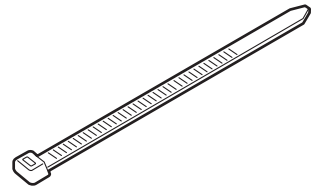

6 EPT sealers

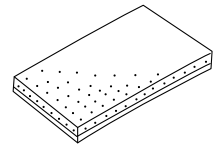

Cushion tape

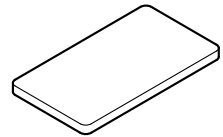

Cover seal

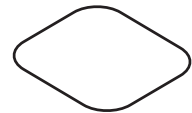

2 Wire ties with clips

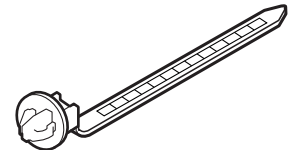

Accessory User's Information Manual

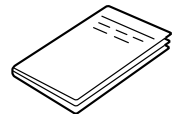

XM Antenna Kit P/N 08A15-0J1-100

Antenna

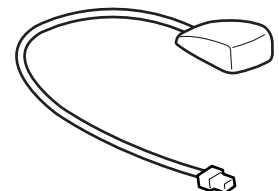

**XM Tuner Kit
P/N 08A15-3J1-001**

XM tuner

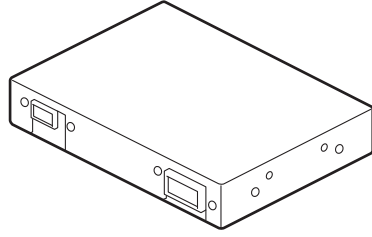

**Bus Cable 2-port Kit
P/N 08A31-0F1-000**

Bus Cable 2-port

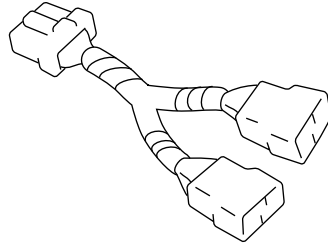

TOOLS AND SUPPLIES REQUIRED

- Phillips screwdriver
- Flat-tip screwdriver
- 10 mm Wrench
- Ratchet
- 8 mm and 10 mm Socket
- Isopropyl alcohol
- Shop towel
- Rubber mallet
- Tape measure
- Scale
- Scissors
- Plastic trim tool (T/N SILTRIMTL10)
- Electrical tape
- Diagonal cutters
- Wooden handle hammer

Illustration of the XM Radio Installed in the Vehicle

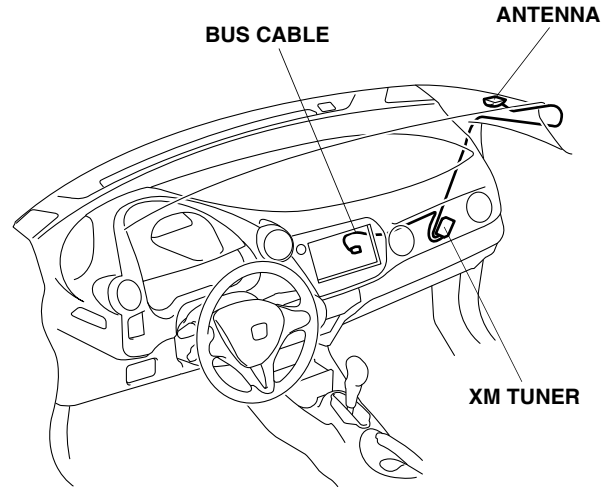

INSTALLATION

Customer Information: The information in this installation instruction is intended for use only by skilled technicians who have the proper tools, equipment, and training to correctly and safely add equipment to your vehicle. These procedures should not be attempted by “do-it-yourselfers.”

1. Make sure you have the anti-theft code for the audio unit or the audio-navigation unit.
2. Disconnect the negative cable from the battery.

3. Pull away the weatherstrip from the right A-pillar trim at the area marked "SIDE CURTAIN AIRBAG."

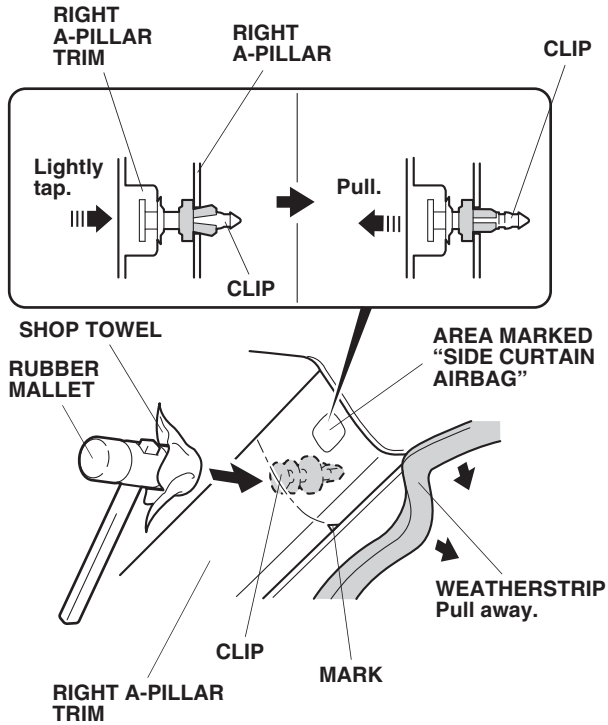

4. Using a rubber mallet wrapped with a shop towel, lightly tap the right A-pillar trim where it says "SIDE CURTAIN AIRBAG" to release the clip.
5. Pull away the rest of the weatherstrip, and remove the right A-pillar trim (two clips).

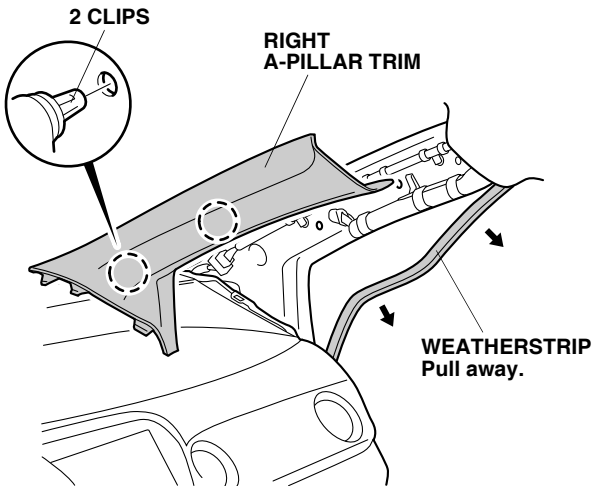

6. Remove the passenger's dashboard undercover (three clips and two pins).

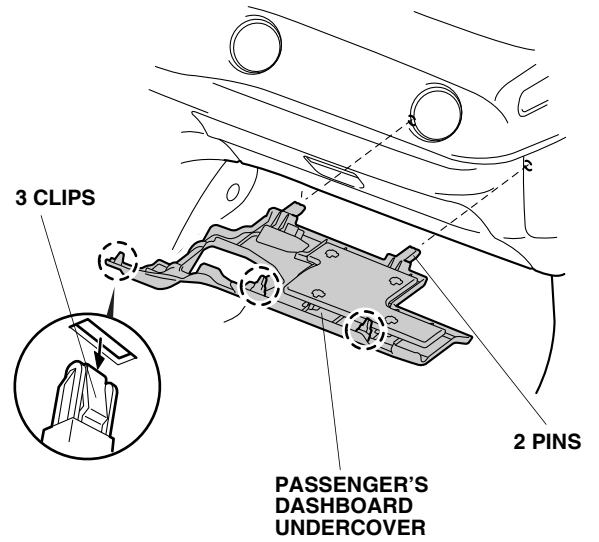

7. Remove the glove box (release the damper rod, two bolts, and two stops).

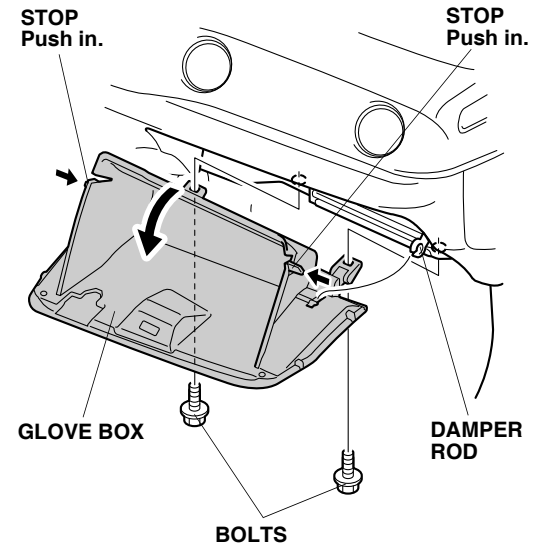

- Remove the right front door sill trim (three clips and five retaining tabs).

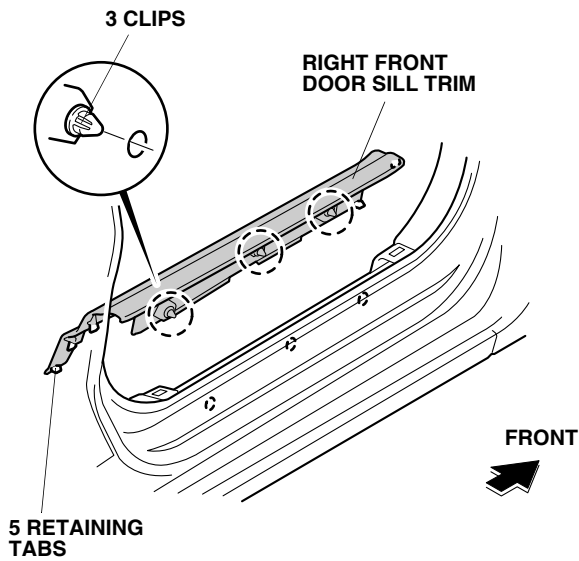

- Pull away the weather-strip, and remove the front passenger's kick panel (two clips).

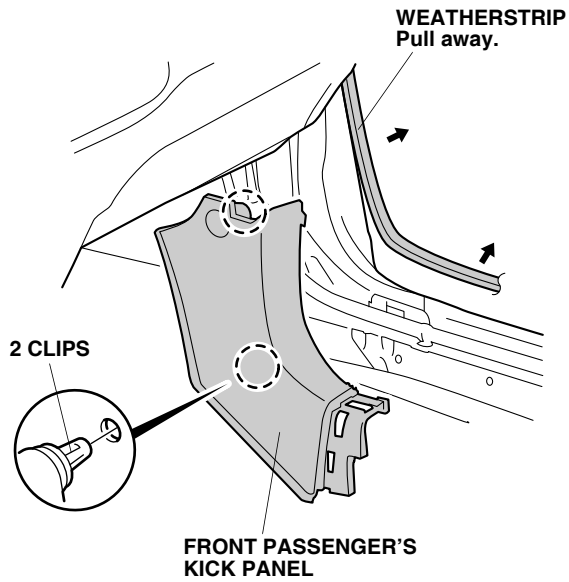

- Remove the center lower trim (six clips, three retaining tabs, and unplug the vehicle connectors).

Without Navigation

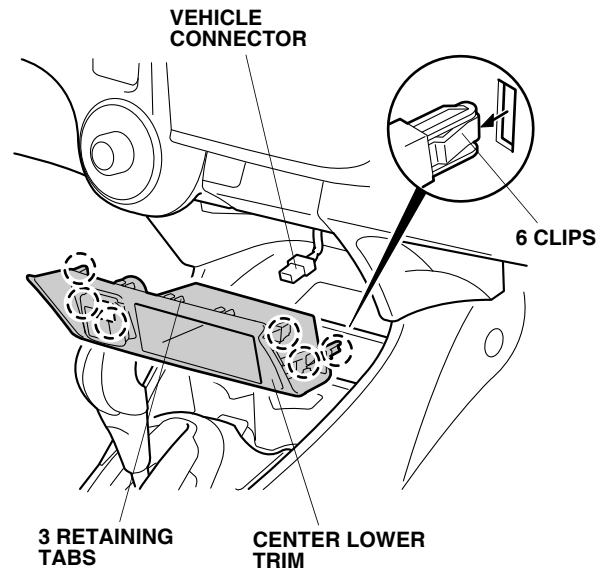

With Navigation

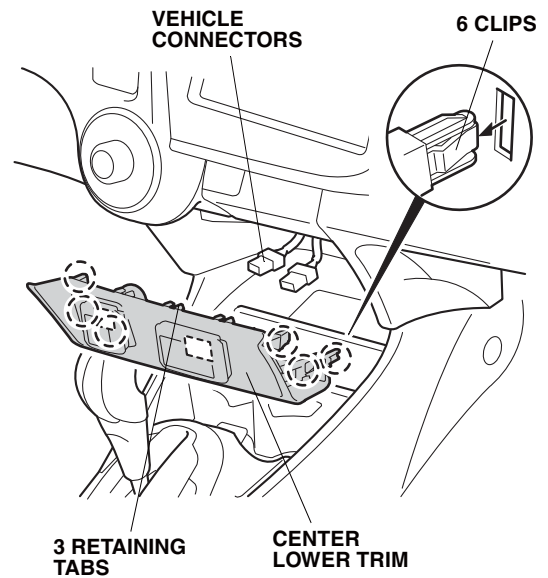

- Reach under the dashboard, and remove the center panel bolt.

Without Navigation: Using the sturdy wooden handle of a hammer, push the back of the audio unit forward to release the eight clips. Release the harness clip, and unplug the vehicle connectors. Carefully remove the audio unit without scratching the dashboard.

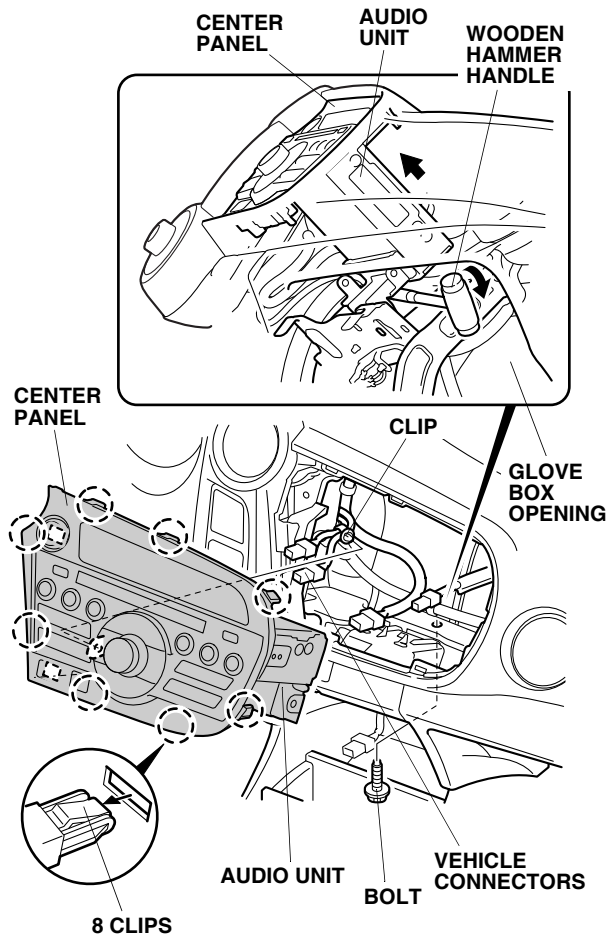

With Navigation: Insert your hand through the glove box opening, and push the back of the navigation unit forward to release the seven clips. Release the harness clip, and unplug the vehicle connectors. Carefully remove the navigation unit without scratching the dashboard.

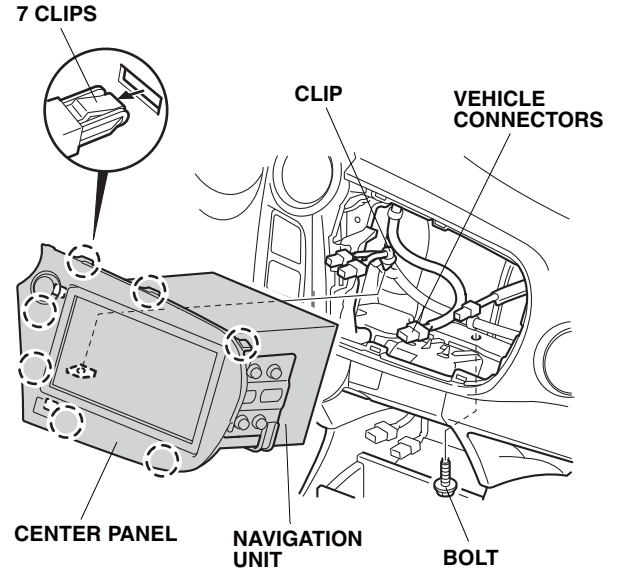

- Attach pieces of electrical tape to the antenna cord at the measurements shown (points A and B).

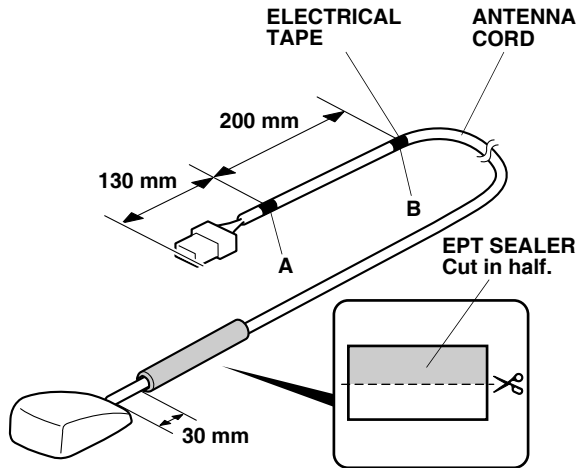

- Using scissors, cut one EPT sealer in half. Wrap one half of the EPT sealer around the antenna cord at the measurement shown.
- Using isopropyl alcohol on a shop towel, thoroughly clean the inside upper corner of the windshield where the antenna will attach.

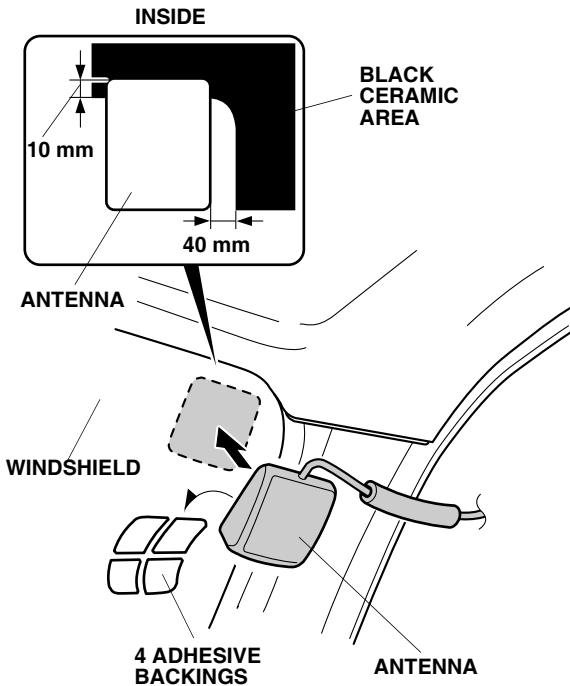

- Remove four adhesive backings from the antenna, and attach the antenna to the windshield as shown. Firmly press the antenna against the windshield to ensure good adhesion.

- Using isopropyl alcohol on a shop towel, thoroughly clean the outside of the windshield where the cover seal will attach. Remove the adhesive backing from the cover seal, and attach the cover seal to the windshield as shown.

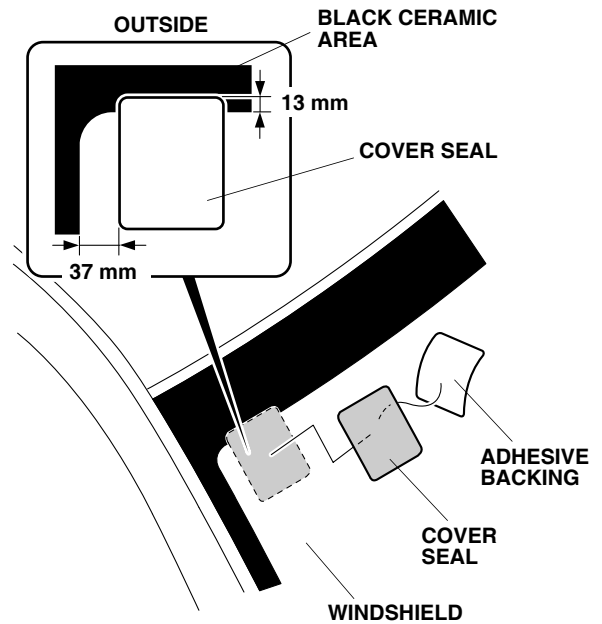

- Inside the vehicle, carefully insert the antenna cord between the vehicle panel and the headliner. Be careful not to crease the headliner.

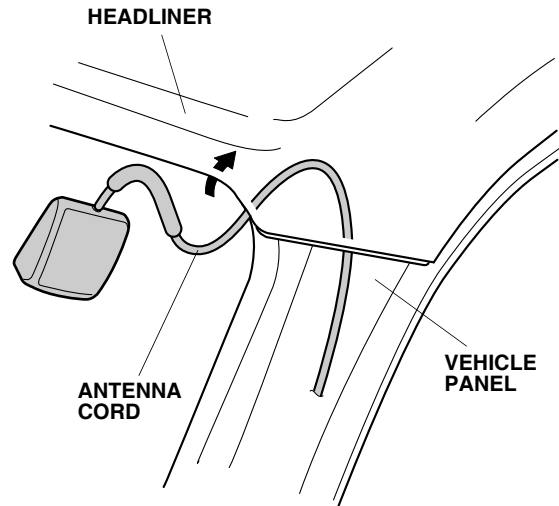

18. Using scissors, cut one cushion tape into four equal pieces.

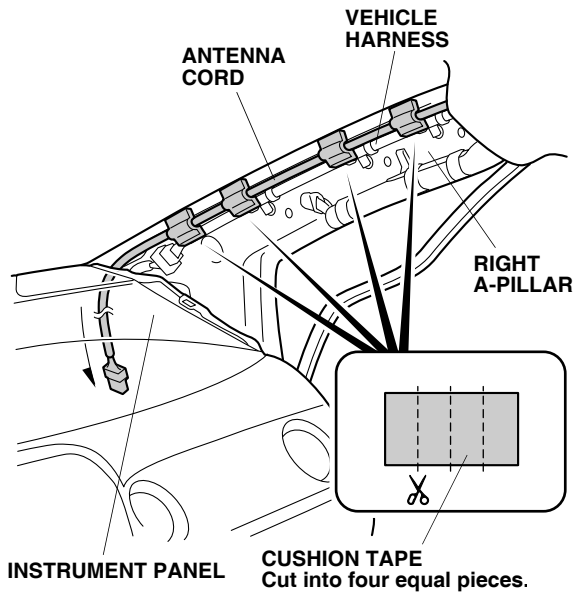

19. Using isopropyl alcohol on a shop towel, thoroughly clean the areas where the cushion tapes will attach.
20. Route the antenna cord along the vehicle harness. Secure the antenna cord to the vehicle harness with four pieces of cushion tape.
21. Using a piece of electrical tape, mark the antenna cord where it touches the dashboard panel.

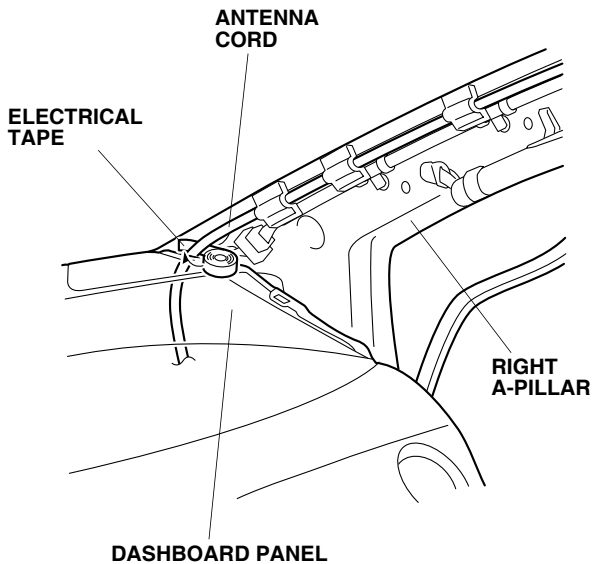

22. Using scissors, cut one EPT sealer in half. Wrap these halves, plus the half remaining from step 13, around the antenna cord. Start at the tape mark you made in step 21 and work downward.

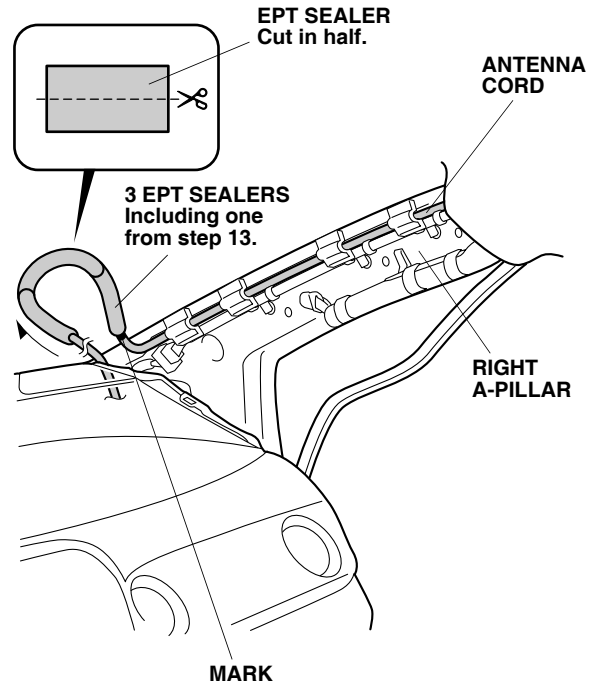

23. Route the antenna cord down to the glove box opening. Loosely secure the excess antenna cord to the vehicle harness with one wire tie.

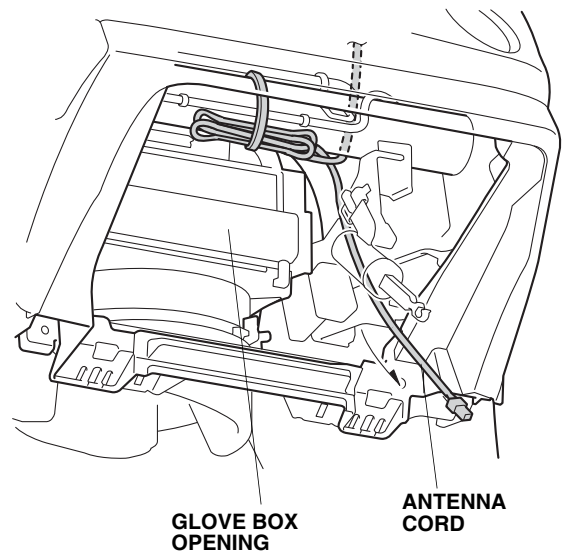

24. Attach three pieces of electrical tape to the bus cable at the measurements shown (points A, B, and C).

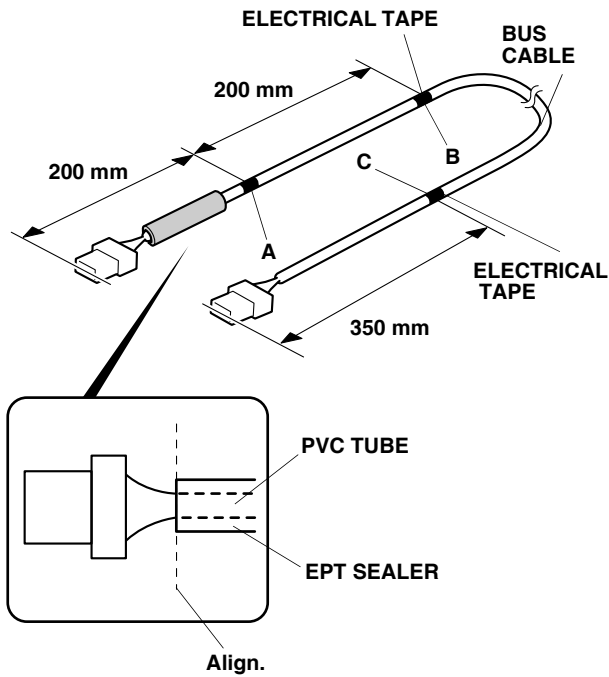

25. Wrap one EPT sealer around the bus cable at the measurement shown.
26. Route the bus cable from the glove box opening to the center panel opening.

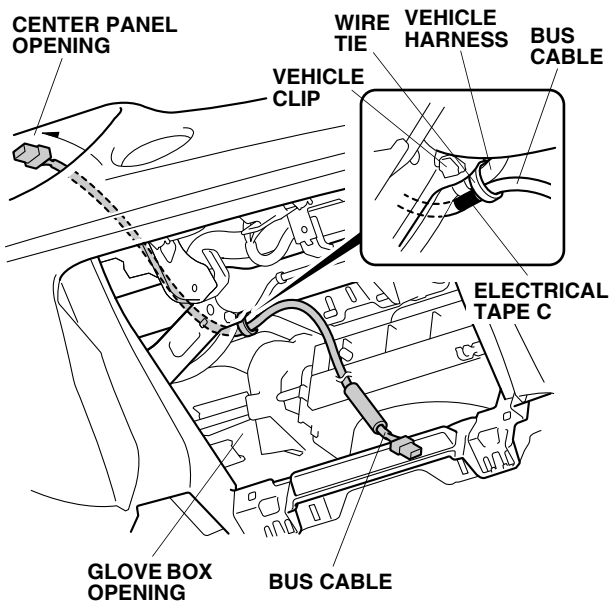

27. Secure the bus cable to the vehicle harness at electrical tape C with one wire tie.

28. Route the bus cable along the steering hanger beam.

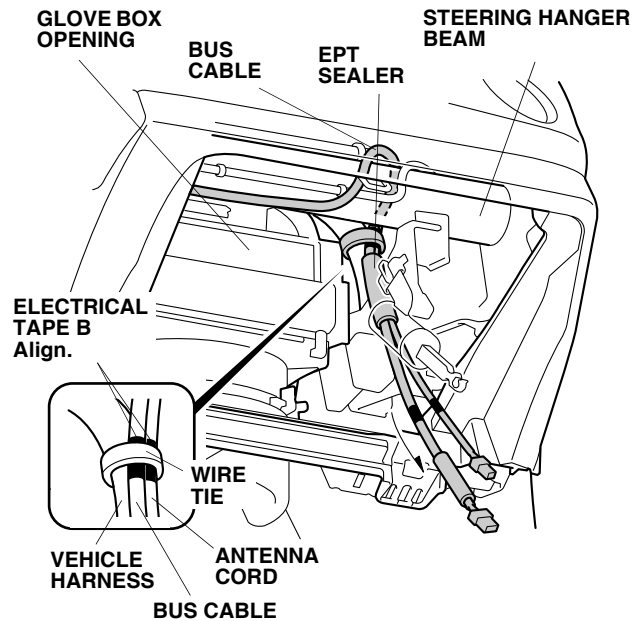

29. Align electrical tape B on the antenna cord (step 12) with electrical tape B on the bus cable as shown. Secure the antenna cord and bus cable to the vehicle harness at electrical tape B with one wire tie as shown.
30. Wrap one EPT sealer around the antenna cord and bus cable at the areas shown.
31. Install one wire tie with clip to the antenna cord and bus cable at electrical tape A as shown.

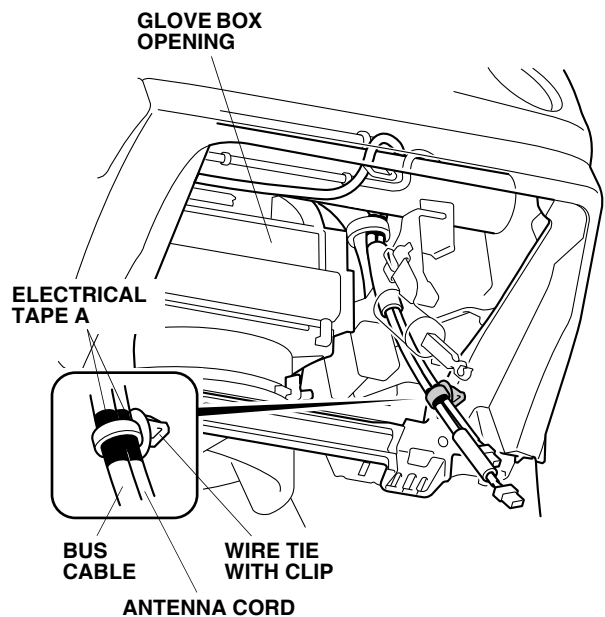

32. Install the XM tuner bracket A to the XM tuner with two 5 x 8 mm washer-screws.
- NOTE: Make sure to install the bracket right side up in the correct position.

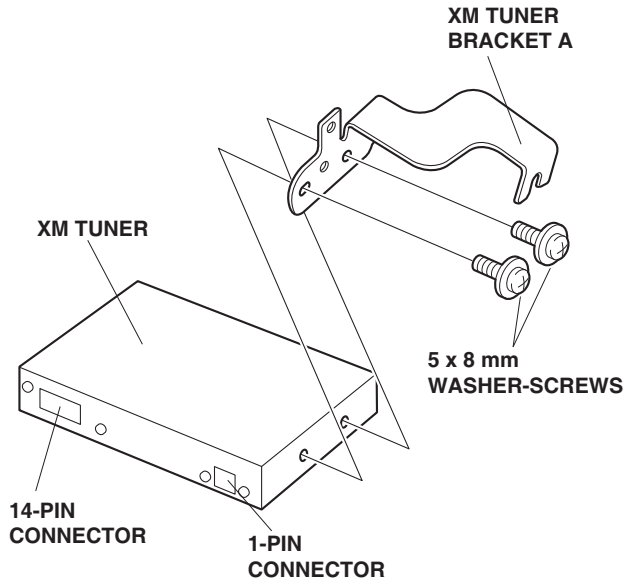

33. Working through the glove box opening, loosen the vehicle nut on the blower motor.

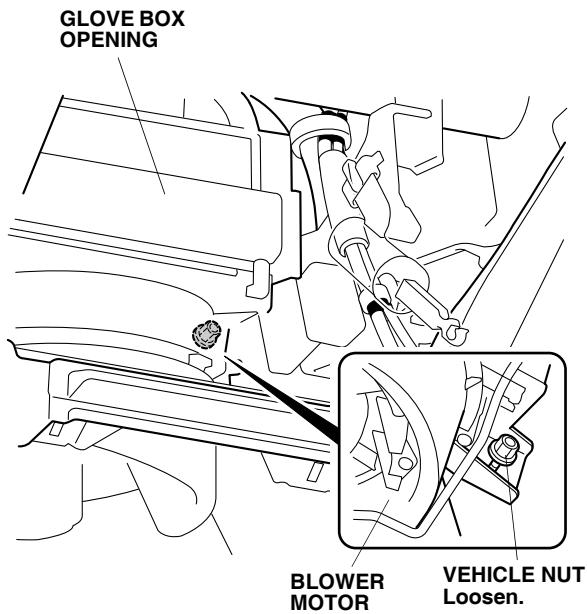

If the vehicle is equipped with HandsFreeLink (HFL), continue with step 34; if not, go to step 36.

34. Remove the vehicle clip from the HFL unit bracket. Using diagonal cutters, cut and remove the vehicle clip.

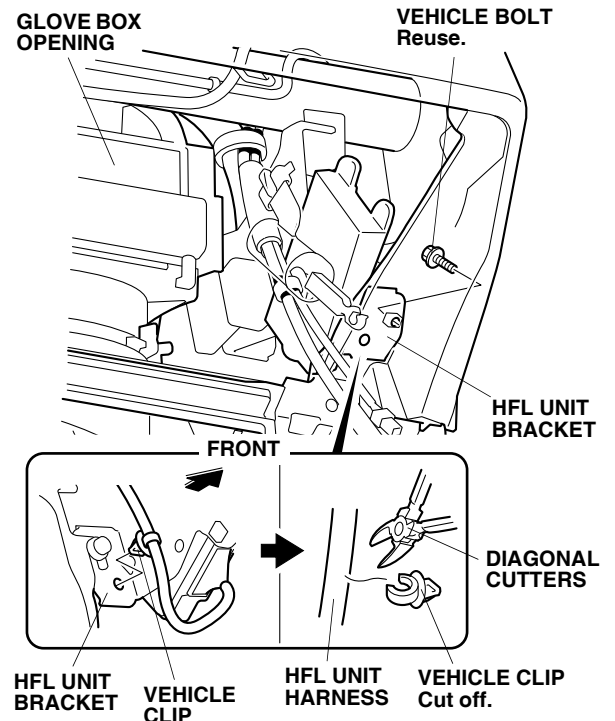

35. Remove the vehicle bolt from the HFL unit bracket.

36. Attach the XM tuner bracket A under the blower motor nut loosened in step 33, but don't tighten the nut yet.

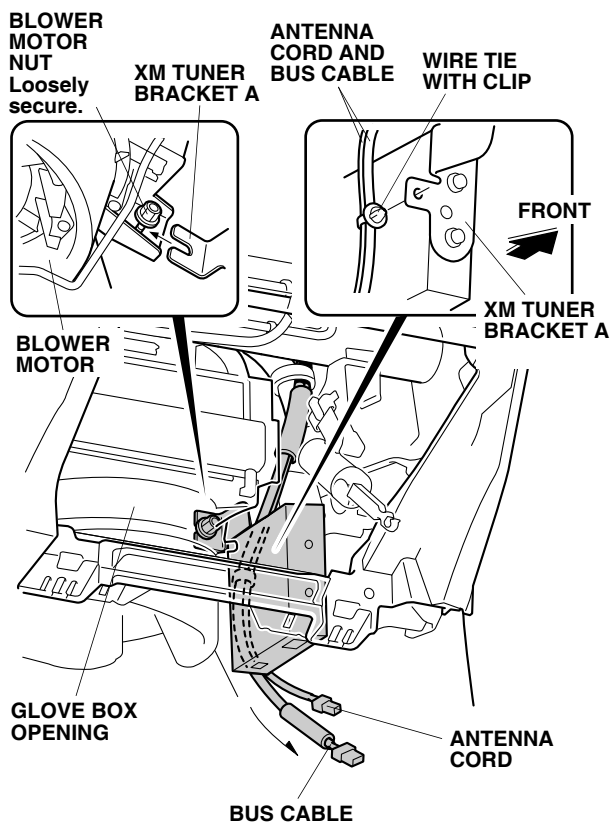

37. Attach the wire tie with clip (installed in step 31) to the XM tuner bracket.
38. Install the XM tuner bracket B to the XM tuner with two 5 x 8 mm washer-screws and two plain washers.

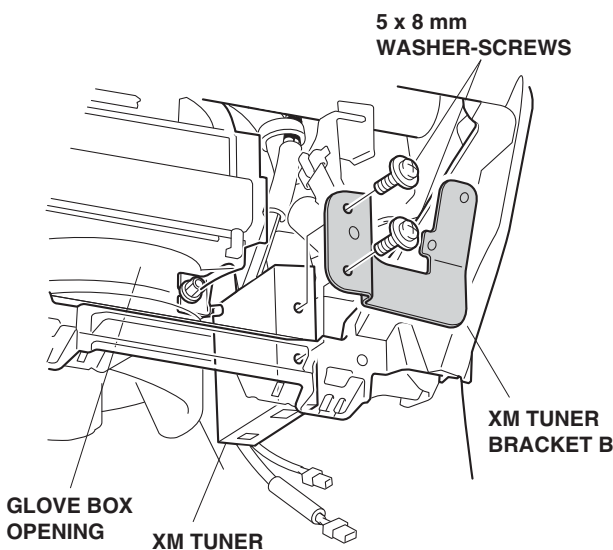

If the vehicle is equipped with HFL, continue with step 39; if not, go to step 42.

39. Secure the XM tuner to the vehicle bracket and the HFL unit bracket with the vehicle bolt removed in step 35.

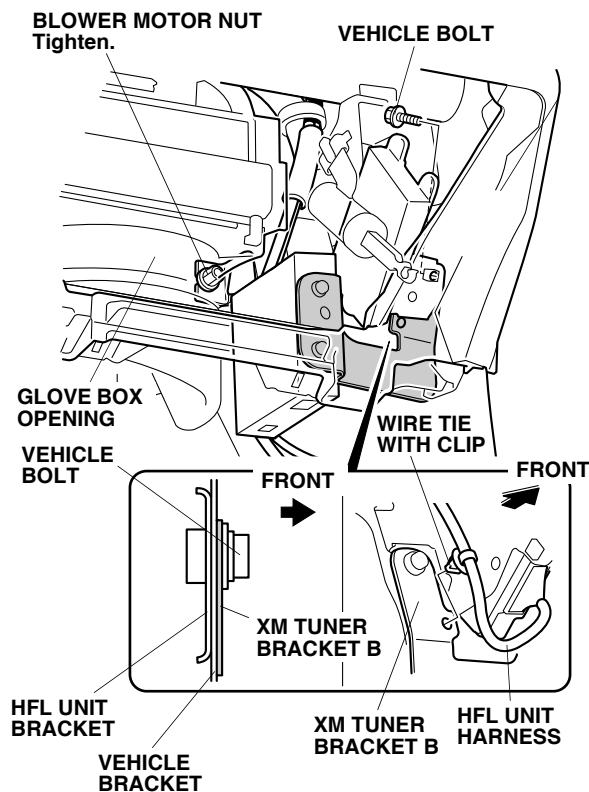

40. Secure the HFL unit harness to the XM tuner bracket B with one wire tie with clip.
41. Tighten the blower motor nut installed in step 36. Go to step 44.

42. Secure the XM tuner to the vehicle panel with one 6 mm washer-nut and one 6 x 16 mm washer-bolt.

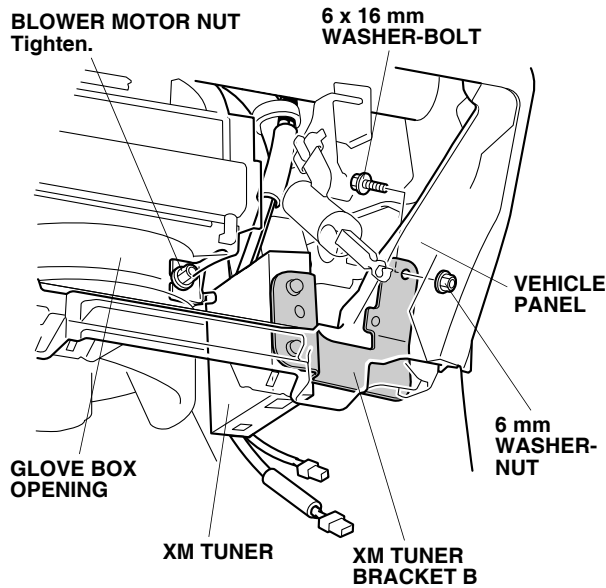

43. Tighten the blower motor nut installed in step 36.
 44. Plug the bus cable 14-pin connector and the antenna cord 1-pin connector into the XM tuner.

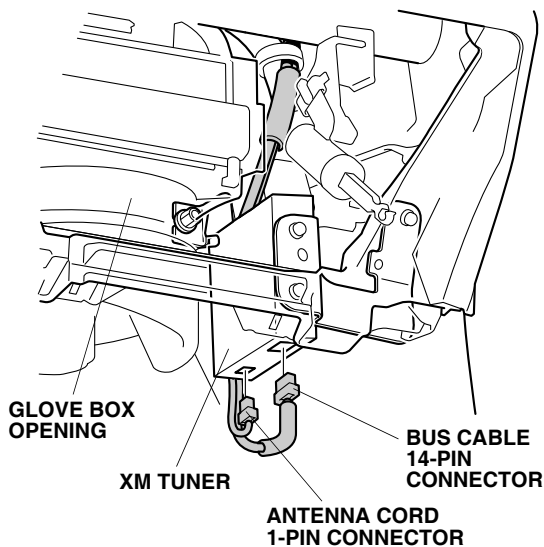

45. If necessary, reposition the excess antenna cord, and tighten the wire tie loosely installed in step 23.

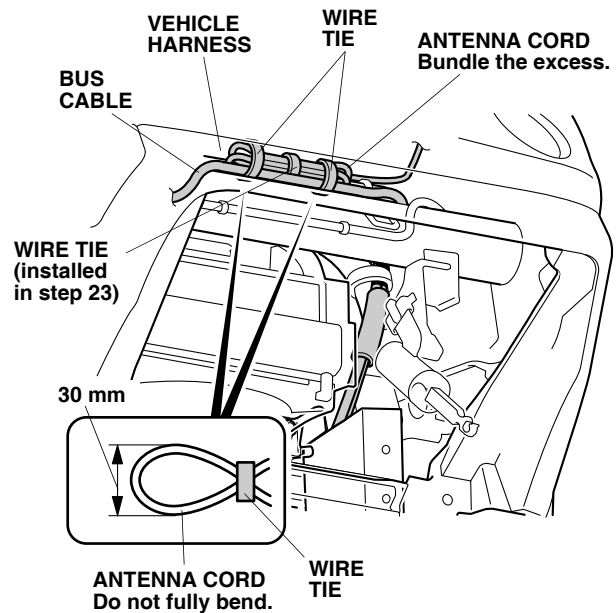

46. Secure the antenna cord and the bus cable to the vehicle harness with two wire ties. Do not bend the antenna cord more than 30 mm.

If the vehicle is equipped with an additional accessory 14-pin connector, continue with step 47; otherwise, go to step 48.

47. Plug the bus cable 14-pin connector and the other 14-pin connector into the bus cable 2-port 14-pin connector. Wrap an EPT sealer around each 14-pin connector.

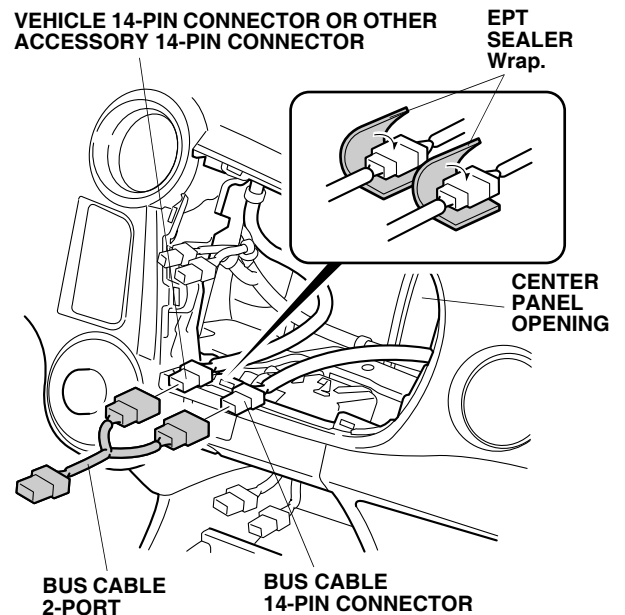

48. Plug the bus cable 14-pin connector into the audio-navigation unit or the audio unit, reconnect the other vehicle connectors, and reinstall the center panel.

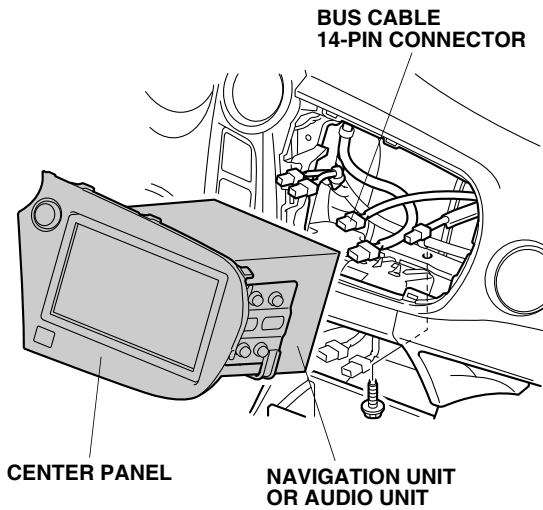

49. Remove and discard the vehicle clip from the right A-pillar, and install the new clip. Reinstall the right A-pillar trim.

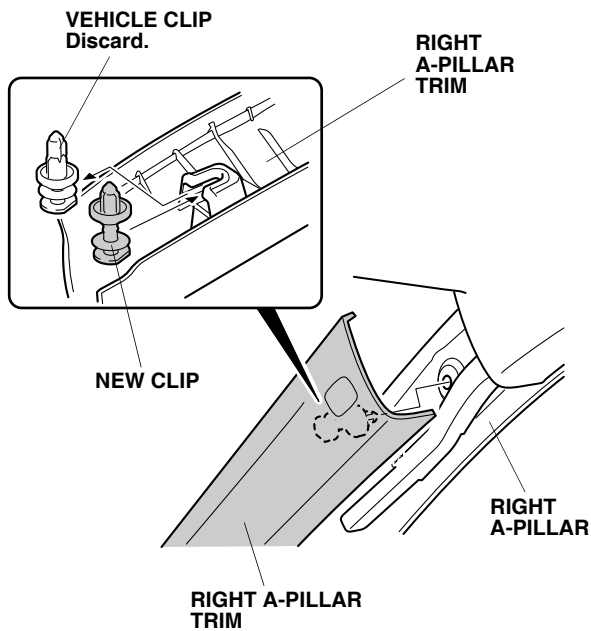

50. Check that all wire harnesses are routed properly and all connectors are plugged in.
51. Reconnect the negative cable to the battery.
52. Enter the customer's audio unit or audio-navigation unit anti-theft code, and reset the radio station presets.
53. Reset the clock.
54. Check the operation of the XM radio system according to the supplied Accessory User's Information Manual.
55. Reinstall all removed parts.