



INSTALLATION INSTRUCTIONS

Accessory
ENGINE BLOCK HEATER
P/N 08T44-SWA-1A0

Application
2012 CR-V

Publications No.
All 12073

Issue Date
DEC 2011

PARTS LIST

Engine block heater

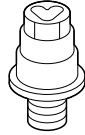

Aluminum washer



Heater harness

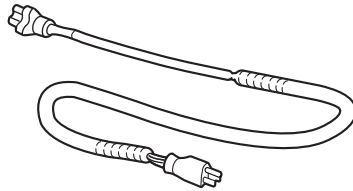

Protective cap

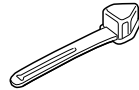

15 Black wire ties
(1 Not used)

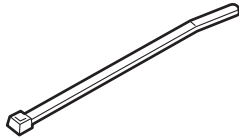

5 Wire ties with clip
(Not used)

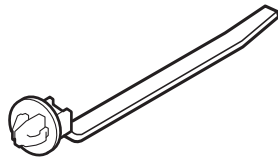

5 White wire ties
(1 Not used)

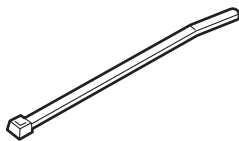

Coolant concentration label



TOOLS AND SUPPLIES REQUIRED

Phillips screwdriver

Flat-tip screwdriver

Long blade flat-tip screwdriver

Ratchet

10 mm, 12 mm, 14 mm, 17 mm, and 24 mm Sockets

Torque wrench

Diagonal cutters

Heavy gloves

Drain pan

Tape measure

White marker

Coolant (Honda All Season Antifreeze/Coolant Type 2)

Eye protection (face shield, safety goggle, etc.)

Blanket

Drill

3 mm and 7 mm Drill bits

15 mm Hole saw

10 mm Hex wrench

Pushpin

Fender cover

10 mm Open end wrench

Tape

Ruler

File

The following tool is available through the Honda Tool and Equipment Program. On the iN, click on: Service > Service Bay > Tool and Equipment Program, then enter the number under "Search." Or call 888-424-6857.

- Plastic Trim Tool (T/N SILTRMTL10)

Illustration of the Engine Block Heater installed on the Vehicle

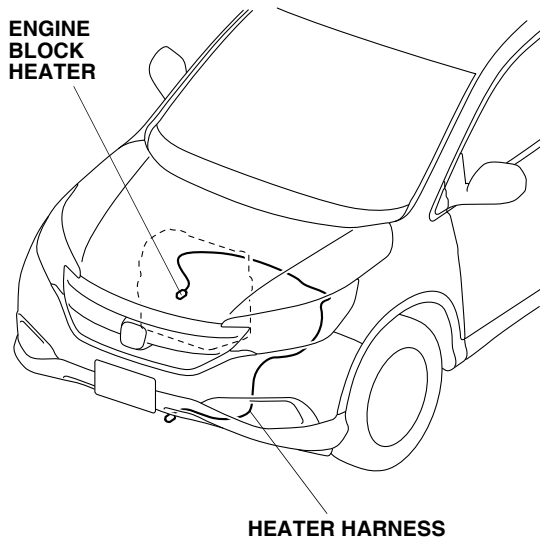

INSTALLATION

NOTE:

- Always use Honda All Season Antifreeze/Coolant Type 2. Using a non-Honda coolant can result in corrosion, causing the cooling system to malfunction or fail.
- To avoid burning out the element, do not operate the engine block heater before it is installed in the vehicle and before you add the coolant.
- Follow the steps 56 through 58 and increase the concentration rate of coolant to 60 ±2%.

Customer Information: The information in this installation instruction is intended for use only by skilled technicians who have the proper tools, equipment, and training to correctly and safely add equipment to your vehicle. These procedures should not be attempted by “do-it-yourselfers.”

1. Disconnect the negative cable from the battery.
2. Allow the engine and all cooling system components to cool down.

3. Place a clean drain pan under the radiator drain plug, then remove the drain plug from the bottom of the radiator to drain the coolant. Remove the radiator cap to increase the flow.

NOTICE: Radiator coolant will damage the body paint. Quickly rinse any spilled coolant from body paint finish.

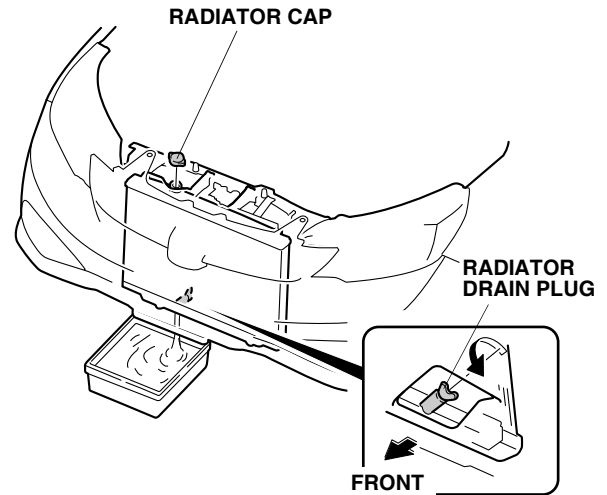

4. Make sure to drain the coolant completely, replace the radiator cap to prevent contamination from entering the radiator.
5. Remove the two self-tapping screws and the three clips from the left front wheel arch protector.

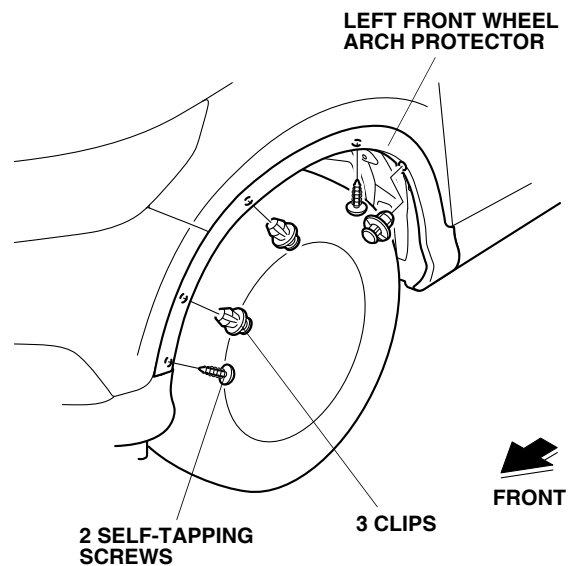

- Remove the left front wheel arch protector (eight clips and three retaining tabs).

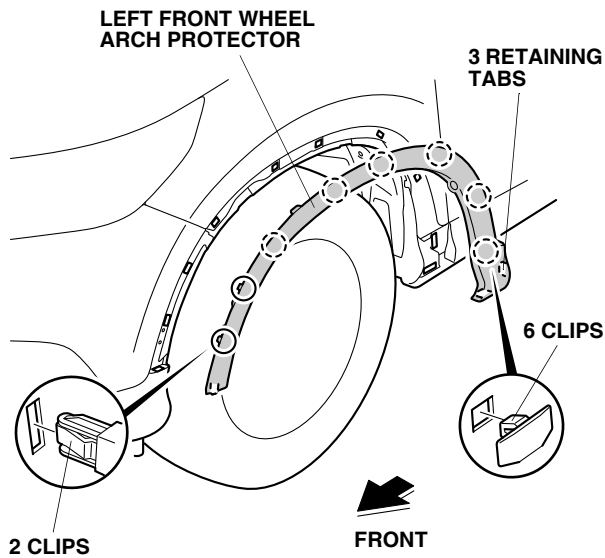

- Repeat steps 5 and 6 to remove the right front wheel arch protector.
- On each side of the vehicle, attach masking tape to the front bumper, left headlight and left front fender as shown.

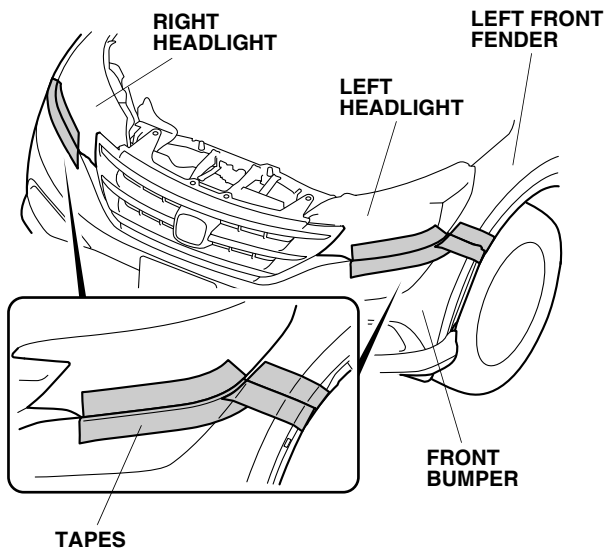

- Attach masking tape to the front grille and front bumper in the area shown.

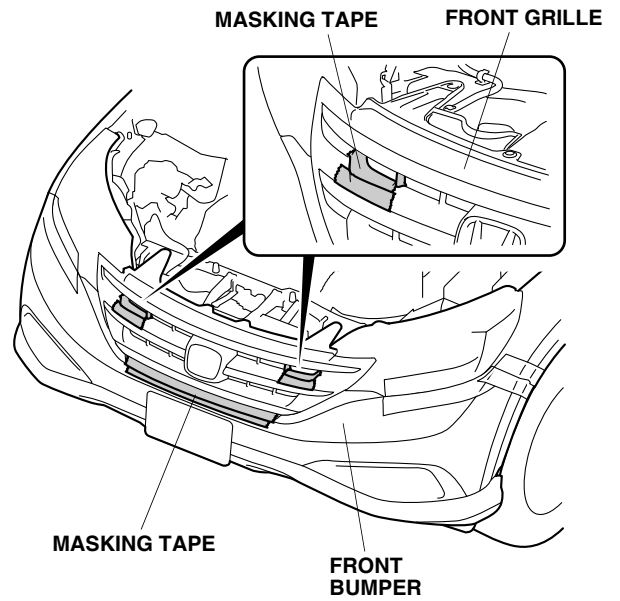

- Remove the four clips from the front grille.

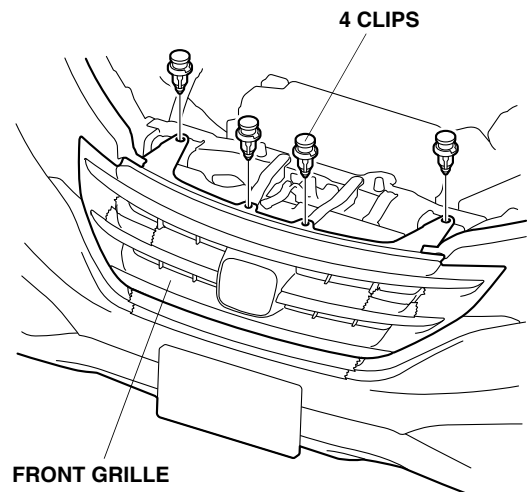

11. Using a flat-tip screwdriver, release the 4 clips from the bottom of the front grille.

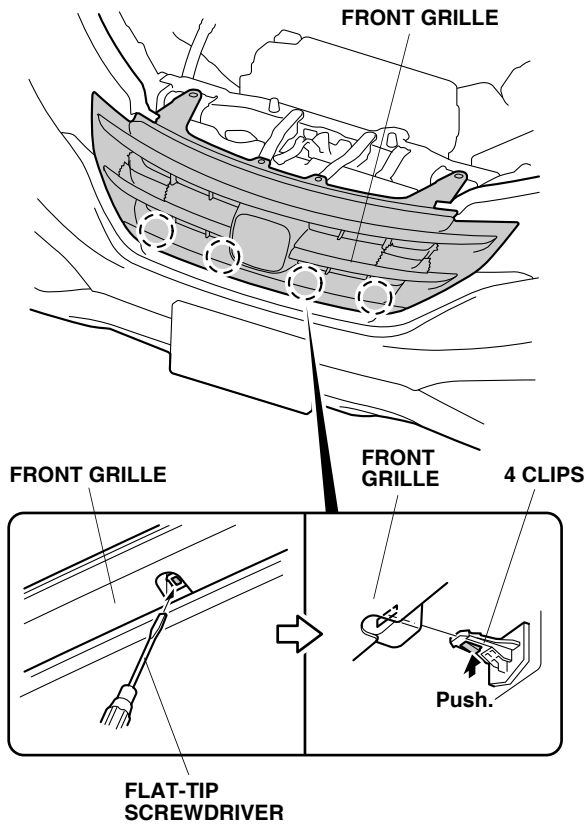

12. Using a long blade flat-tip screwdriver, release the one clip and the two retaining tabs from each side of the front grille.

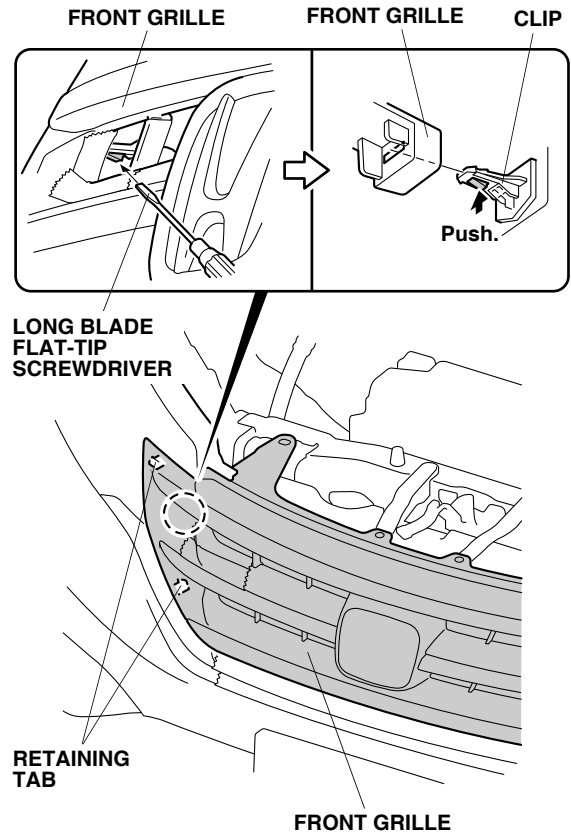

13. Remove the front bumper.

- Remove the two self-tapping screws, two bolts, and six clips.

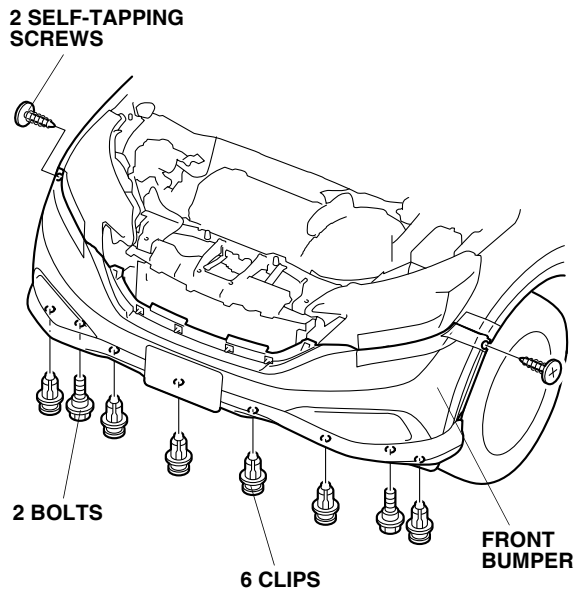

- On each side, release the three retaining tabs.

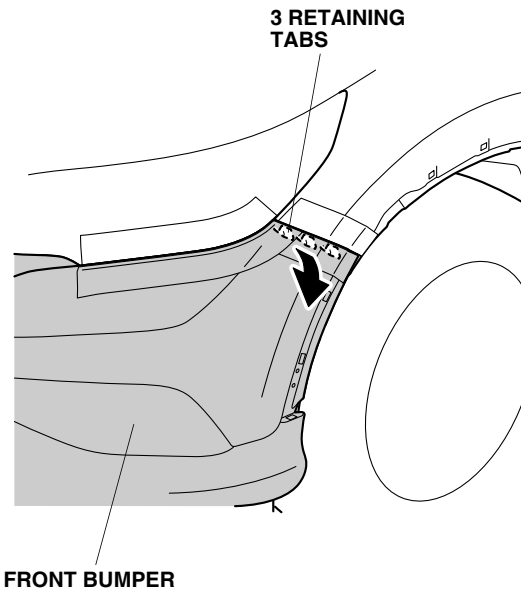

- On each side, release the four retaining tabs.

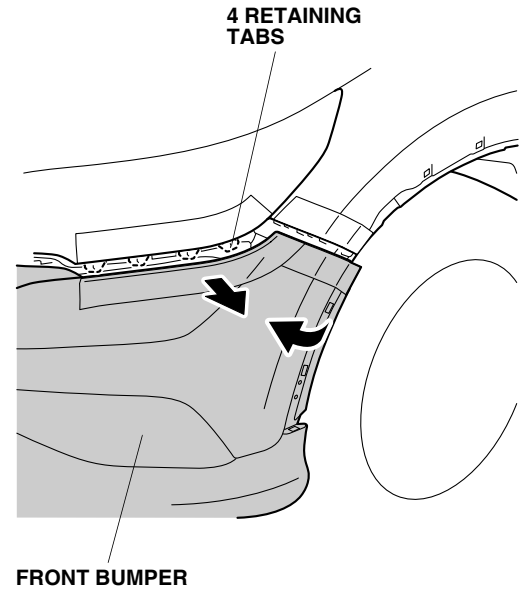

- Attach masking tape to the front bumper in the area shown.

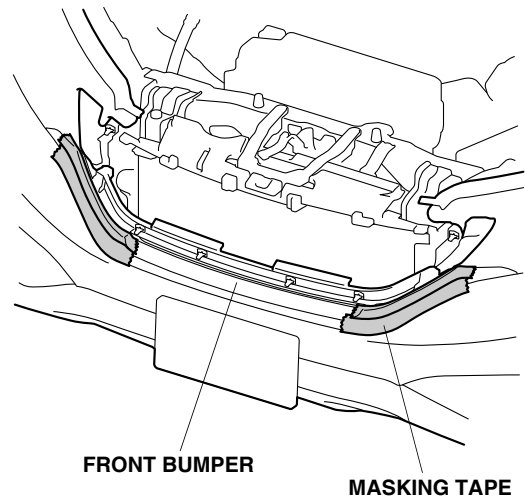

- Release the two clips.
- With the help of an assistant, remove the front bumper (if equipped, unplug the vehicle connectors).
- Place the front bumper on a blanket after removal.

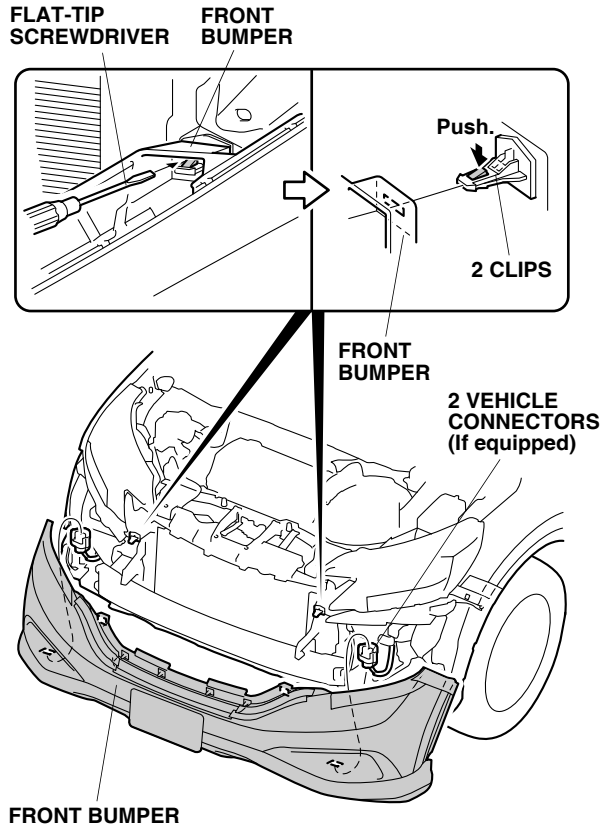

14. On each side, attach pieces of masking tape to the windshield below the blade on the windshield wiper arms to mark the location of the wiper.

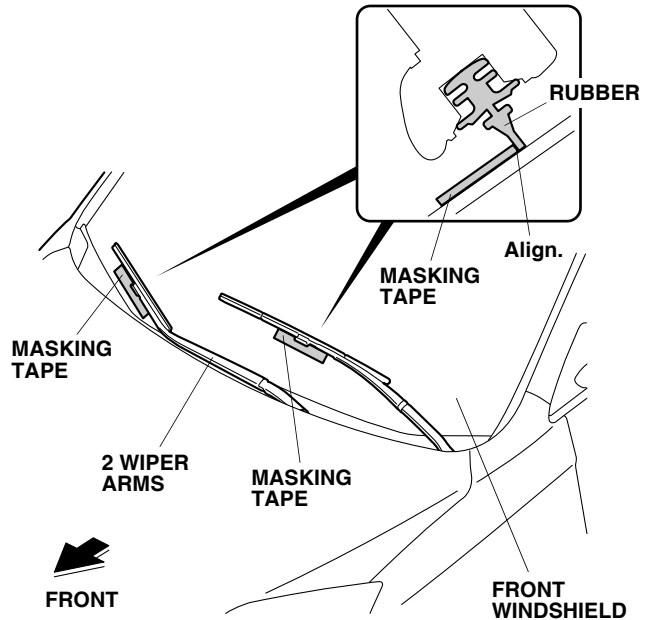

15. Remove the two windshield wiper arms (two caps and two nuts). Wiper arm nut torque is 29.4 N·m (21.6 lbf-ft).

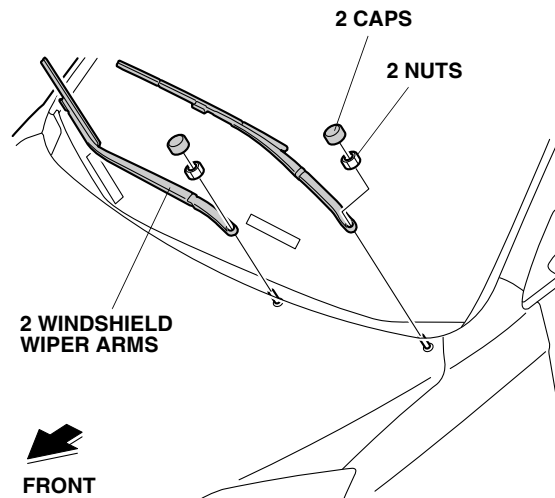

16. Remove the left cowl top cover (four retaining tabs).

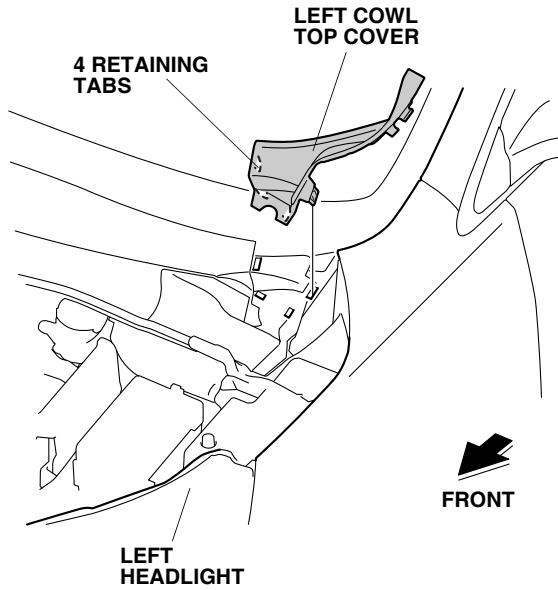

17. Remove the left front fender trim (one clip and three clips).

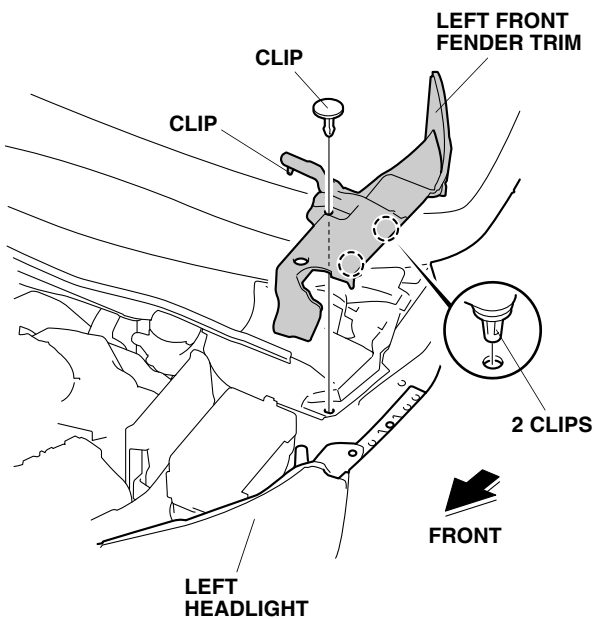

18. Remove the washer tube from the right cowl top cover.

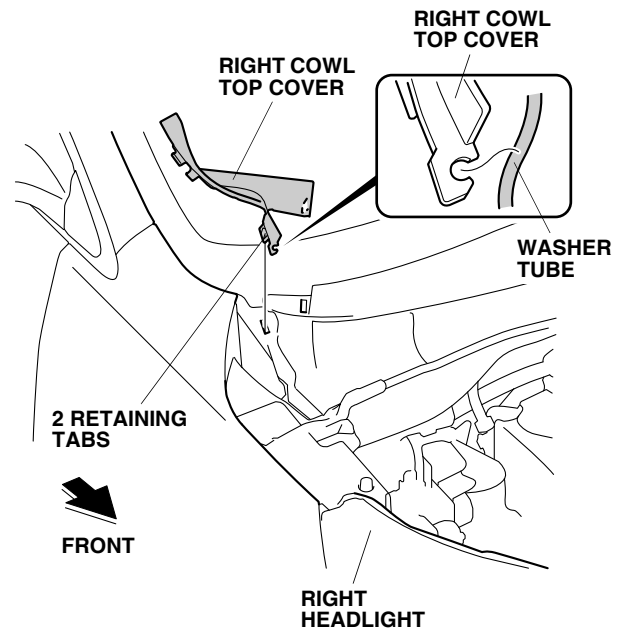

19. Remove the right cowl top cover (two retaining tabs).

20. Remove the right front fender trim (one clip and three clips).

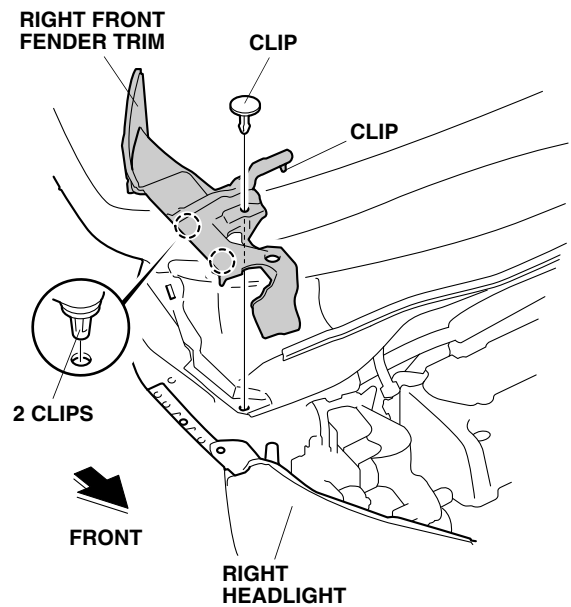

21. Remove the cowl cover (five clips and nine hooks).

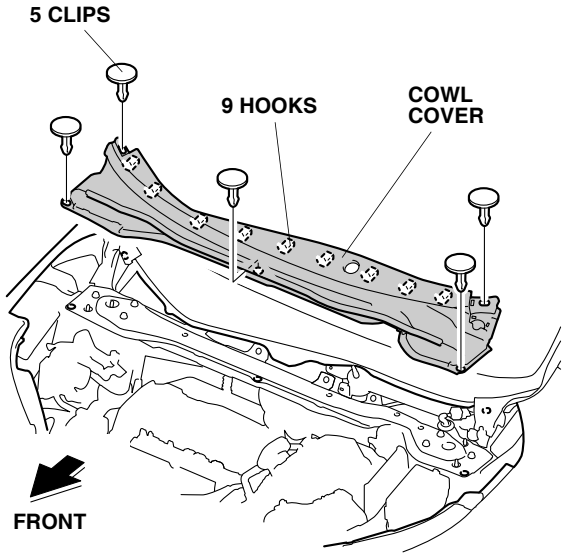

22. Remove the six nuts from the under cowl panel.

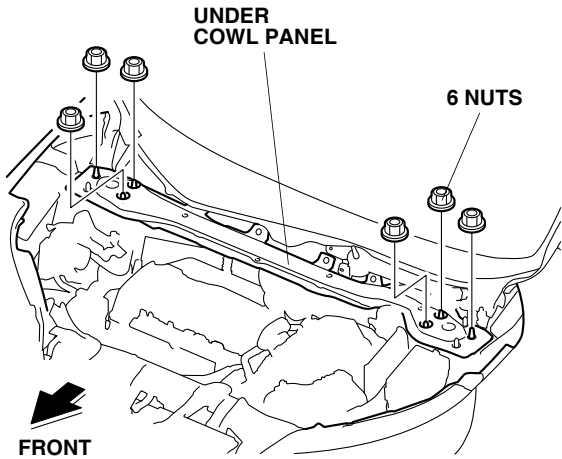

23. Unplug the vehicle connector, and remove the grommet.

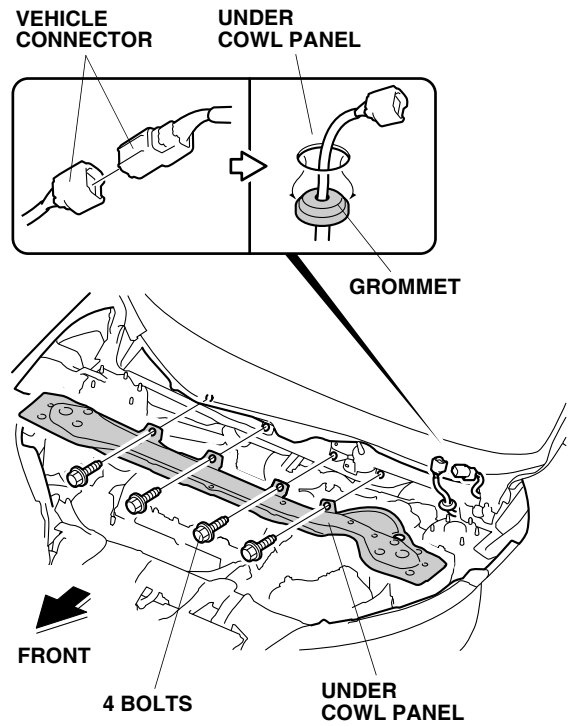

24. Remove the under cowl panel (four bolts).

25. Loosen the air duct clamp. Remove the air cleaner housing cover (sensor connector, one clip, and three hooks).

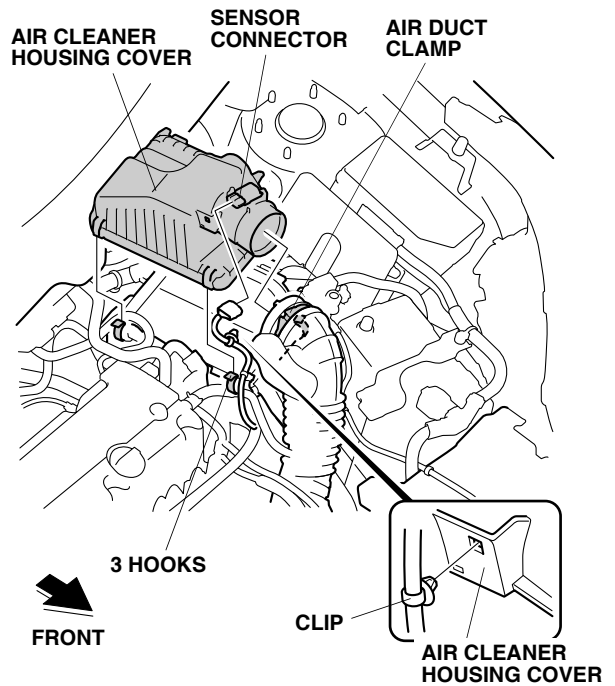

26. Remove the air cleaner housing (one bolt and two pins).

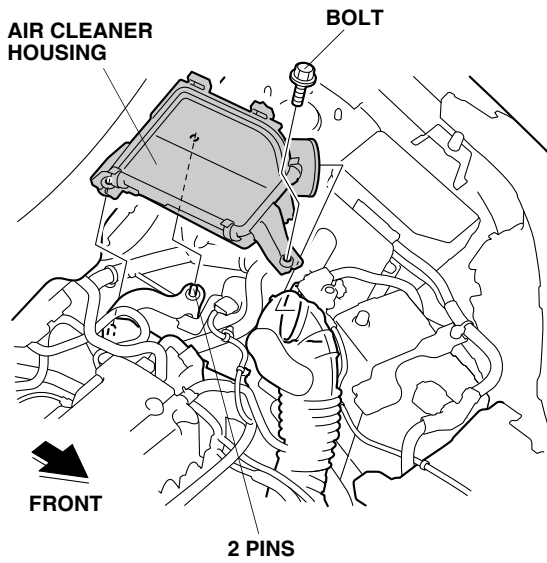

27. Open the positive cable cover, and disconnect the positive cable from the battery.

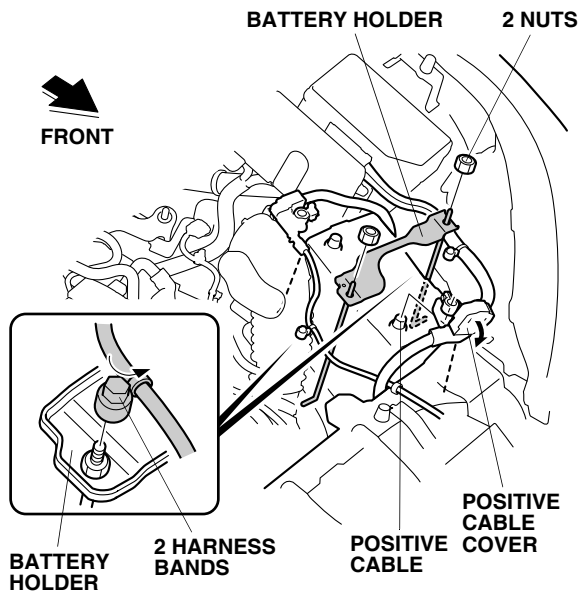

28. Remove the two battery holder covers and harness bands.

29. Remove the two nuts from the battery holder.

30. Remove the battery cover, battery, and battery tray.

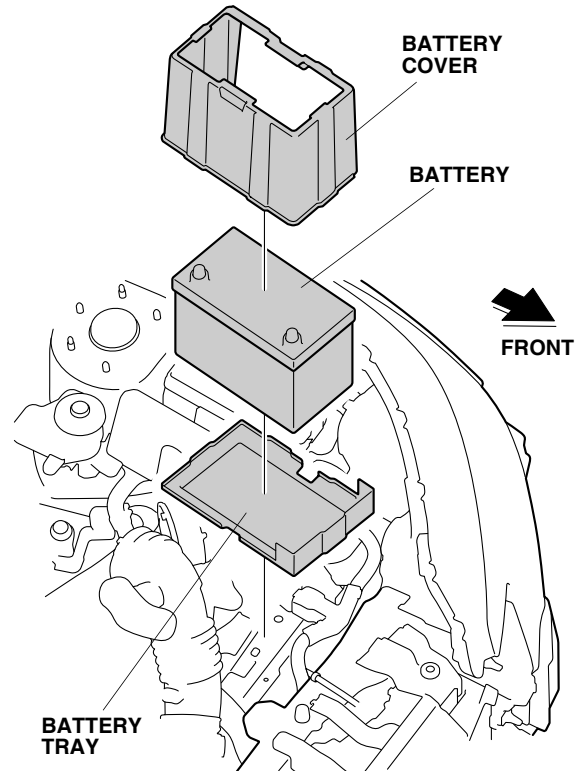

31. Remove the air intake tube (one bolt).

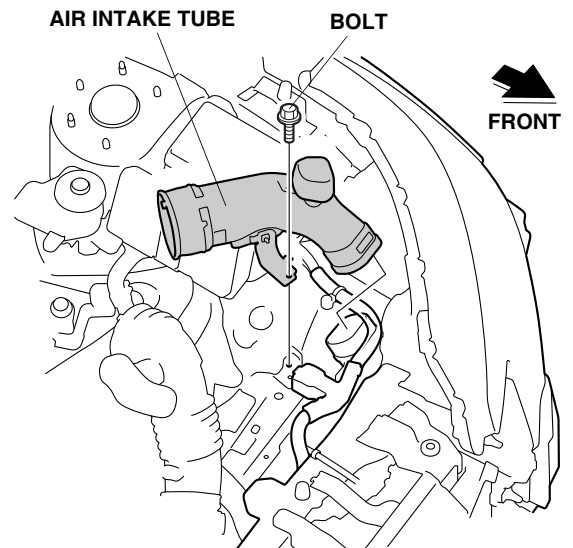

32. Remove the intake air resonator (two bolts).

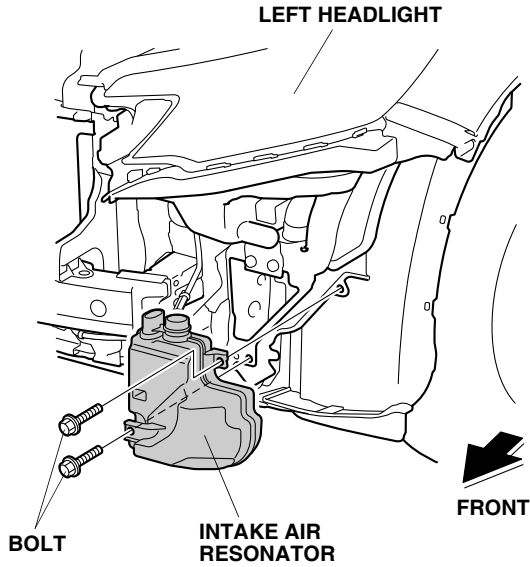

33. Remove the air intake tube (two bolts).

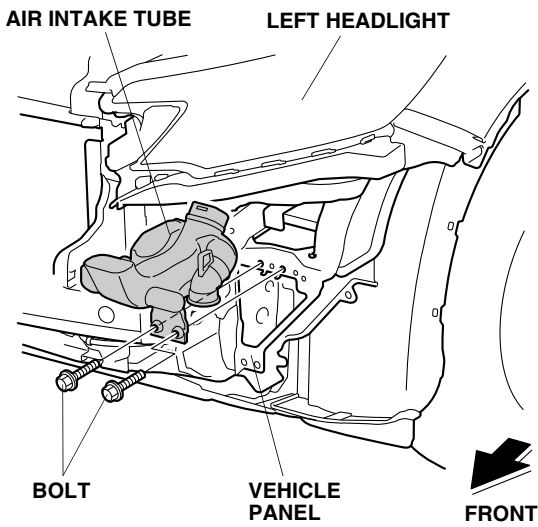

34. Unplug two vehicle connectors.

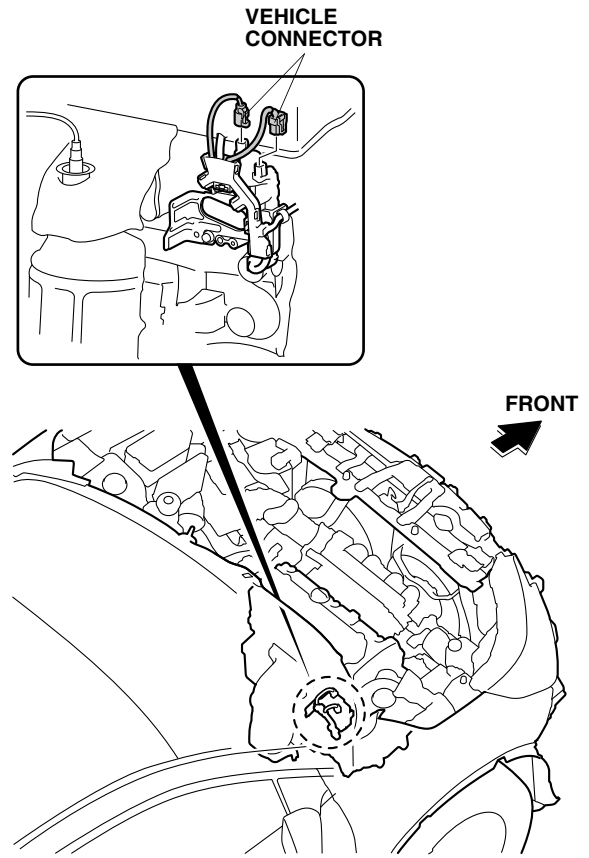

35. Release the vehicle harness holder from the vehicle bracket (two hooks).

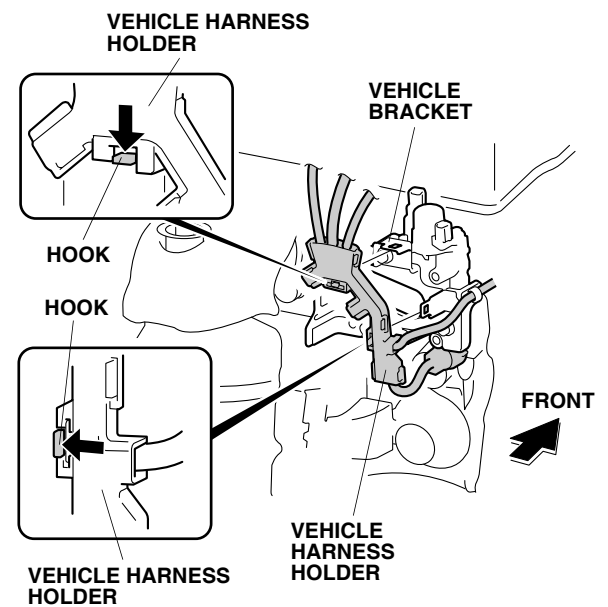

36. Locate and remove the engine block drain bolt. Coolant remaining in the engine jackets flows out of the bolt hole when the bolt is removed. Retain the bolt; it will be used if the engine block heater is removed.

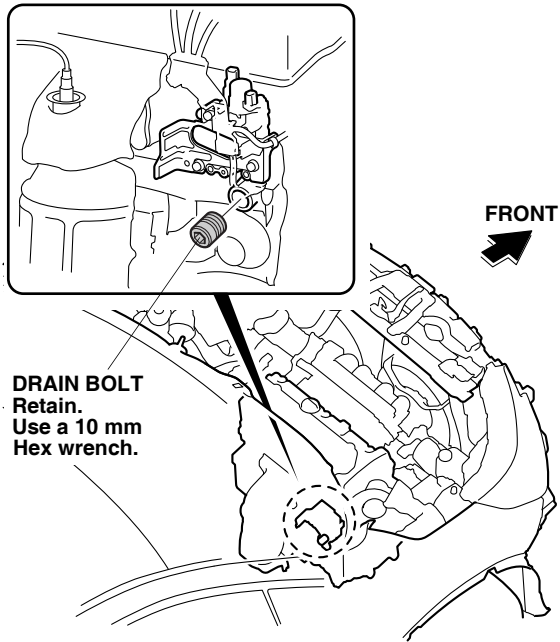

37. Install the new aluminum washer and the engine block heater into the bolt hole using a 24 mm socket and a torque wrench. Torque the engine block heater to 60 N·m (44 lbf·ft).

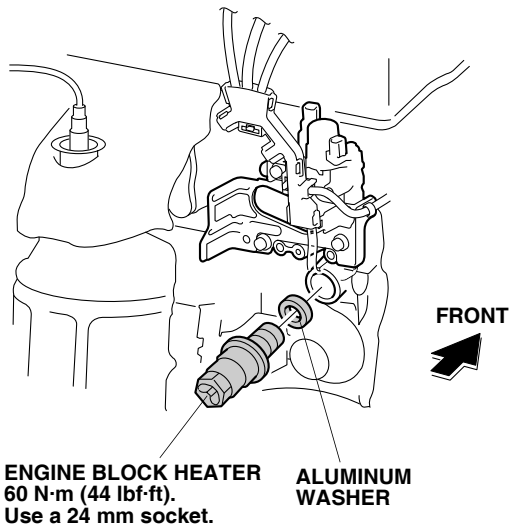

38. Using a tape measure, measure the heater harness and mark it at the A, B, C, and D points shown.

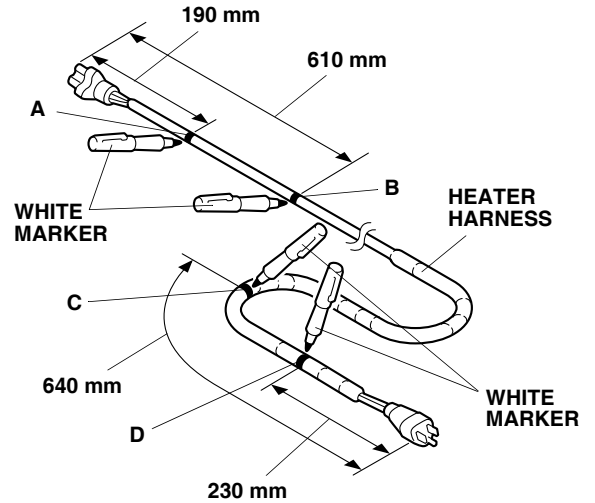

39. Plug the heater harness connector to the engine block heater. Make sure that the heater harness connector is properly installed.

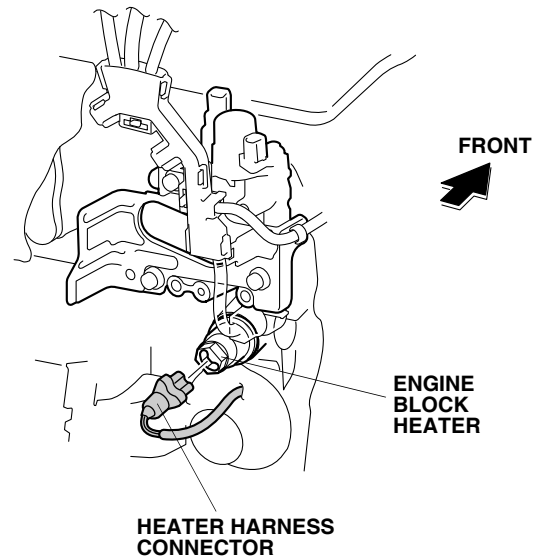

40. Align the mark at point A with the vehicle clip, and secure the heater harness to the vehicle harness with white wire tie.

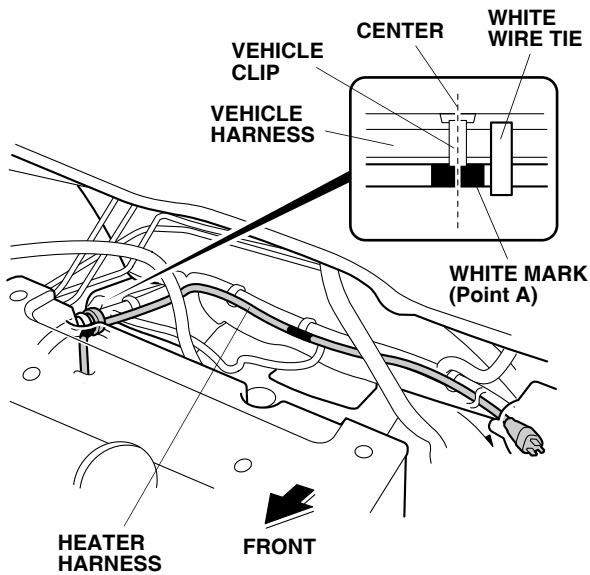

41. Align the mark at the point B with the vehicle clip, and secure the heater harness to the vehicle harness with three white wire ties and one black wire tie as shown.

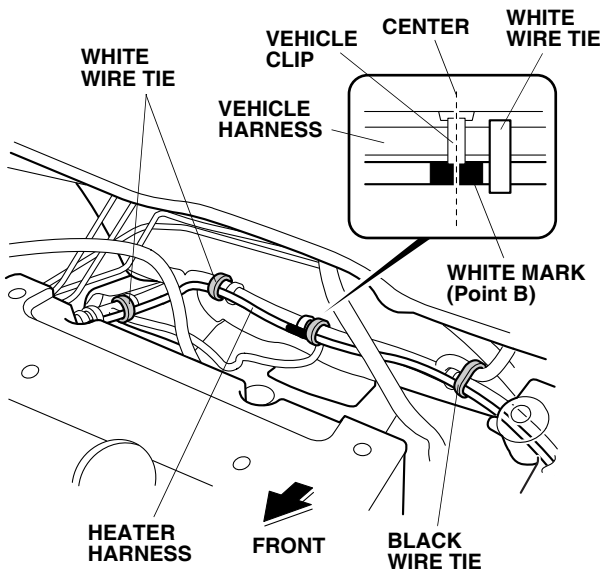

42. Route the heater harness to the driver's side of the fuse box as shown.

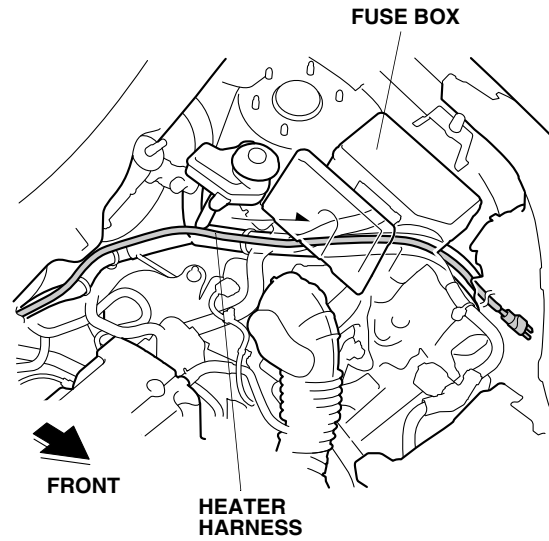

43. Route the heater harness forward along the vehicle harness.

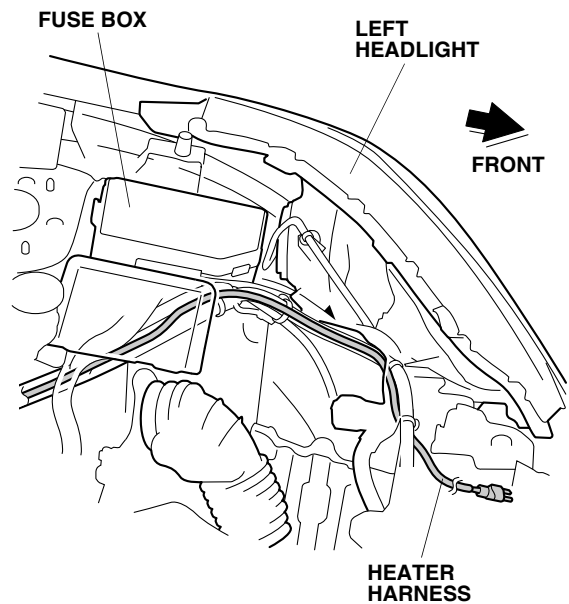

44. Route the heater harness through the front bulkhead as shown.

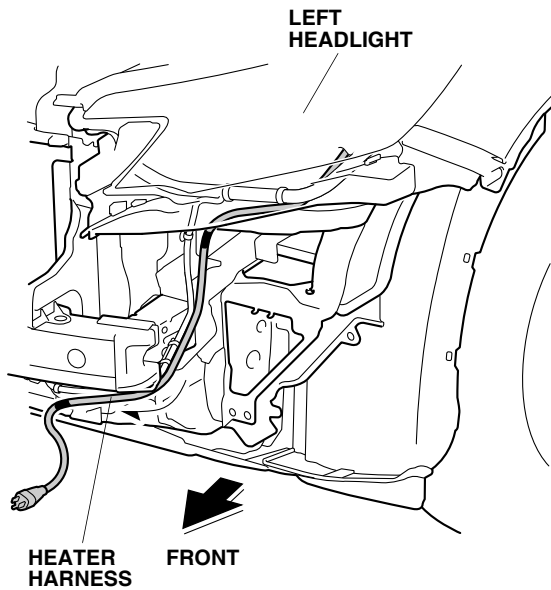

45. Align the mark at point C and D with the vehicle clip, and secure the heater harness to the vehicle harness with five black wire ties as shown.

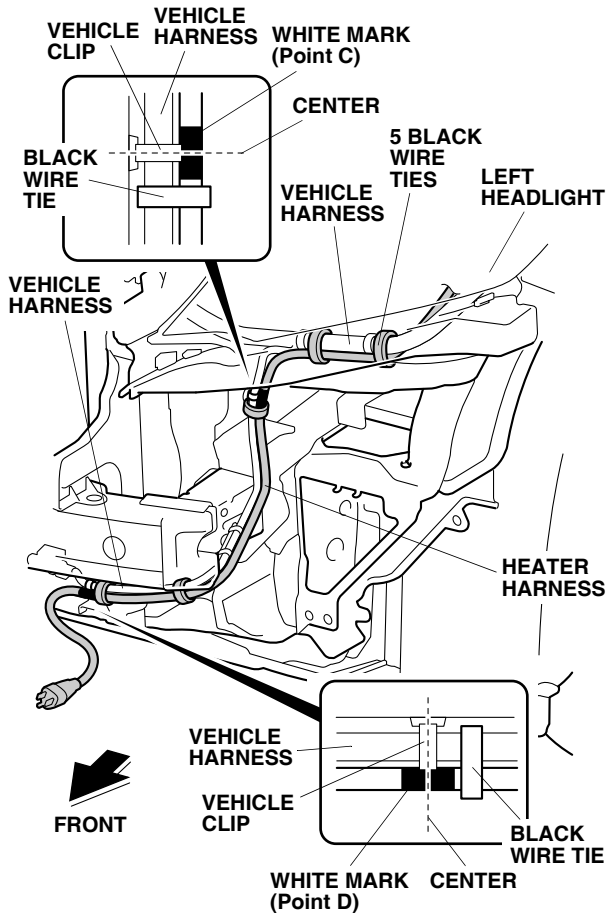

46. Near the fuse box, secure the heater harness to the vehicle harness with two black wire ties.

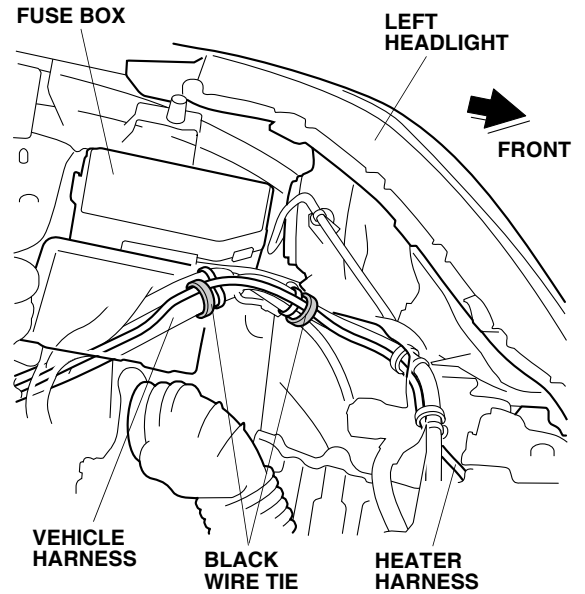

47. Across the top of the engine, secure the heater harness to the vehicle harness with five black wire ties.

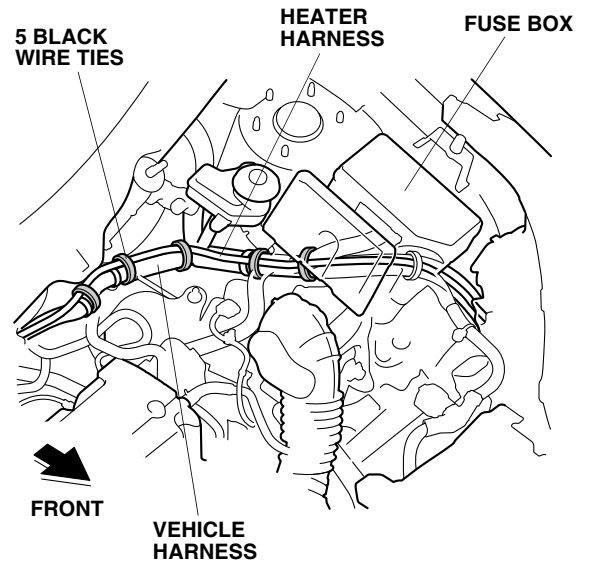

48. Get the front bumper. Measure and mark the front bumper at the measurements shown. Using a pushpin, pierce two marks on the front bumper.

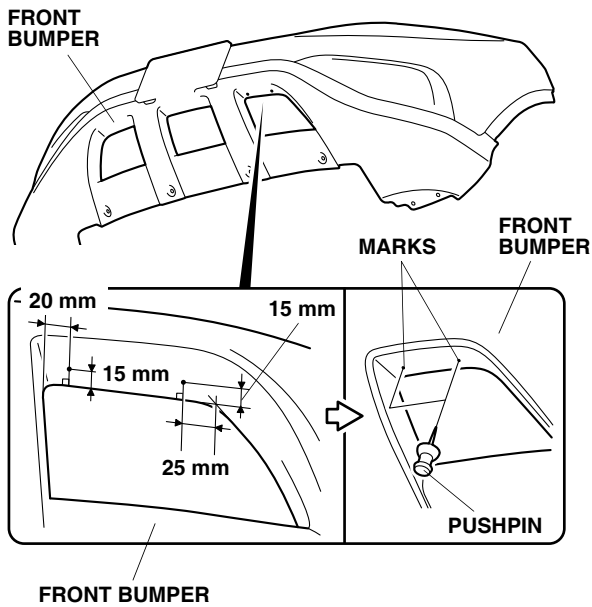

49. While wearing eye protection, drill both pierced marks using a 3 mm drill bit.

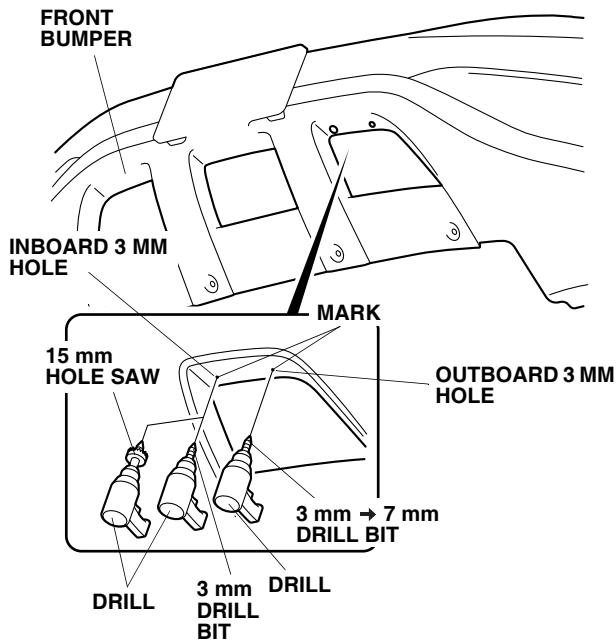

50. Using a 7 mm drill bit, enlarge the outboard 3 mm hole to 7 mm. Using a 15 mm hole saw, enlarge the inboard 3 mm hole to 15 mm.

51. Install the protective cap through the 15 mm hole on the front bumper.

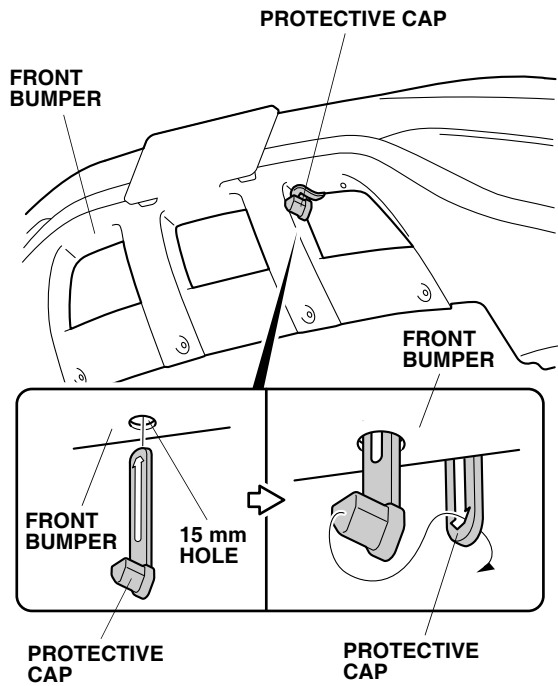

- With the help of an assistant, reinstall the front bumper.

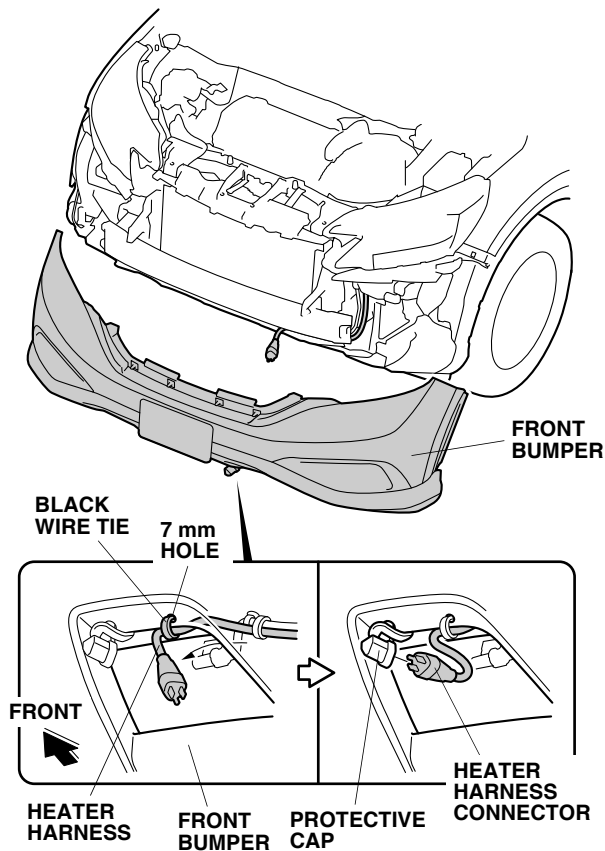

- Secure the heater harness to the front bumper with one black wire tie through the 7 mm drilled hole.
- Install the heater harness connector to the protective cap.
- Reinstall all removed parts.
- Remove the radiator cap, and pour 1.5 lit. of the 100% concentration coolant through the radiator filler port.
- Pour the 50% concentration coolant up to the top of the radiator filler port.
- Check the coolant reservoir for correct level and check the cooling system for signs of leakage. Repair as necessary.
- Check that the heater harness is routed properly and all connectors are plugged in.
- Place the drain bolt (removed in step 37) in the glove box.

- Install the coolant concentration label to the radiator as shown.

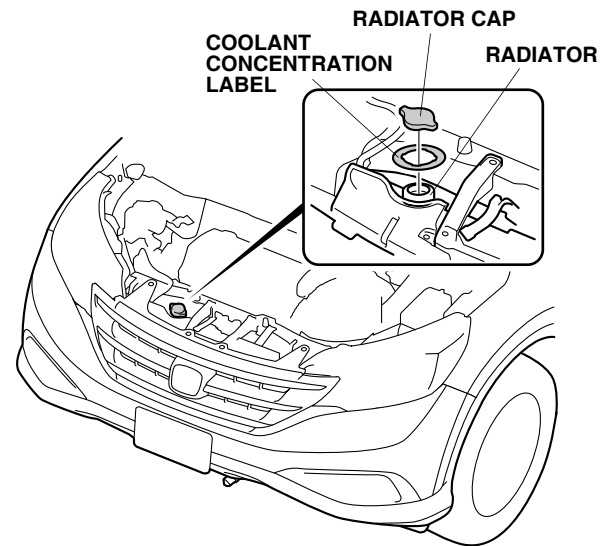

- Reinstall the radiator cap to the radiator.
- Reconnect the negative cable to the battery.
- Press and hold the radio power button for two seconds to restore the radio and navi (if equipped) system functions.
- Reset the clock on vehicles without navigation.