



# INSTALLATION INSTRUCTIONS

Accessory  
**ENGINE BLOCK HEATER**  
P/N 08T44-SNA-101

Application  
**2010 ELEMENT**

Publications No.  
**All 42675**  
Issue Date  
**SEPT 2009**

## PARTS LIST

Engine block heater

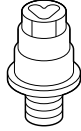

Aluminum washer



Heater harness

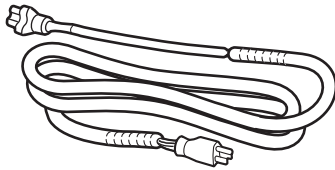

Protective cap

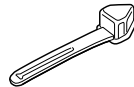

12 Black wire ties  
(2 Not used)

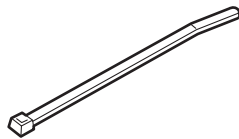

7 Wire ties with clip  
(6 Not used)

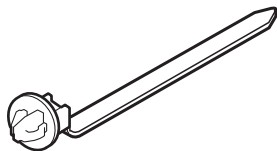

5 White wire ties  
(3 Not used)

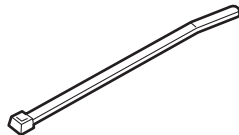

## TOOLS AND SUPPLIES REQUIRED

Phillips screwdriver

10 mm, 12 mm, and 24 mm Sockets

100 mm Extension

Torque wrench

Diagonal cutters

Honda All Season Antifreeze/Coolant Type 2

White marker

Tape measure

10 mm Hexagon wrench

Heavy gloves

Drain pan

Fender cover

Clip remover

**NOTE:** Using longer extension may damage the engine block heater while torquing.

## INSTALLATION

### NOTE

- Always use Honda All Season Antifreeze/Coolant Type 2. Using a non-Honda coolant can result in corrosion, causing the cooling system to malfunction or fail.
- To avoid burning out the element, do not operate the engine block heater before it is installed in the vehicle and before you add coolant.

**Customer Information:** The information in this installation instruction is intended for use only by skilled technicians who have the proper tools, equipment, and training to correctly and safely add equipment to your vehicle. These procedures should not be attempted by “do-it-yourselfers.”

1. Disconnect the negative cable from the battery.
2. Allow the engine and all cooling system components to cool down.

- Place a clean drain pan under the radiator drain plug, then remove the drain plug from the bottom of the radiator to drain the coolant. Remove the radiator cap to increase the flow.

**NOTICE:** Radiator coolant will damage paint. Quickly rinse any spilled coolant from painted surfaces.

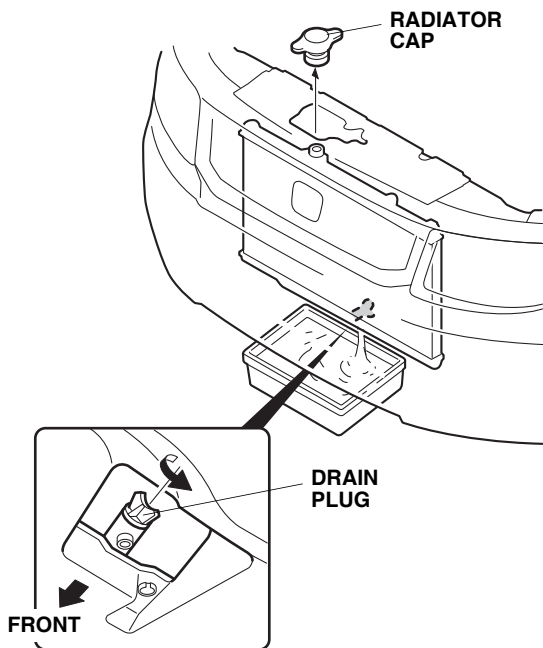

- Remove the radiator cover (five clips).

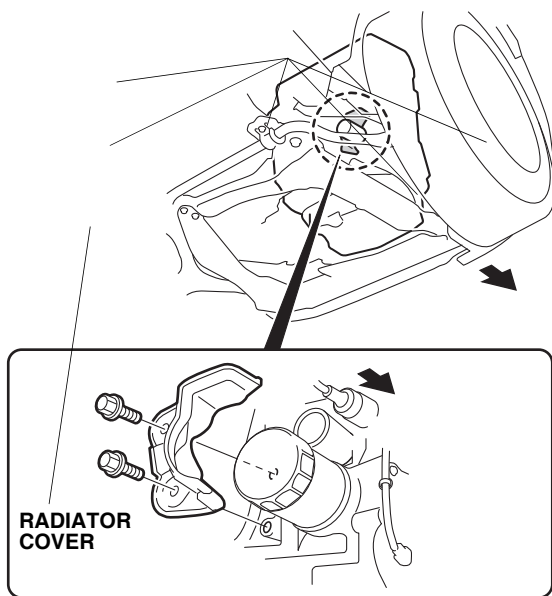

- Remove the front bumper (five clips, four stepped bolts, and four self-tapping screws). Have an assistant help you when removing and installing the front bumper.

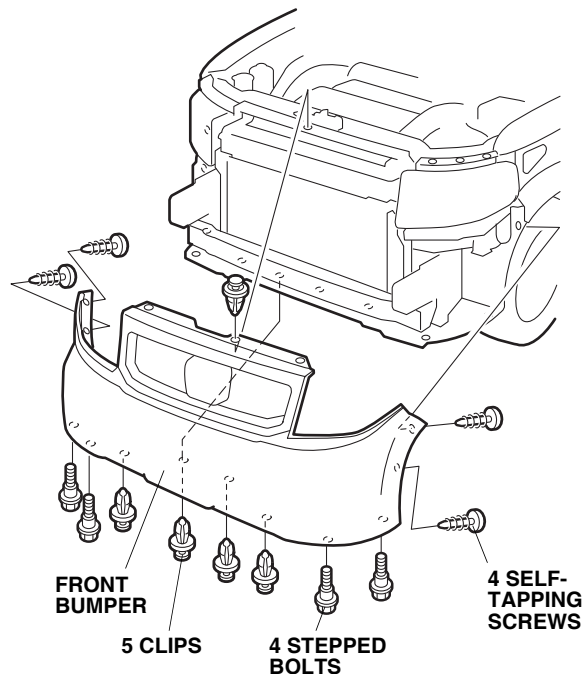

- Lift up the vehicle as described in the Service Manual.

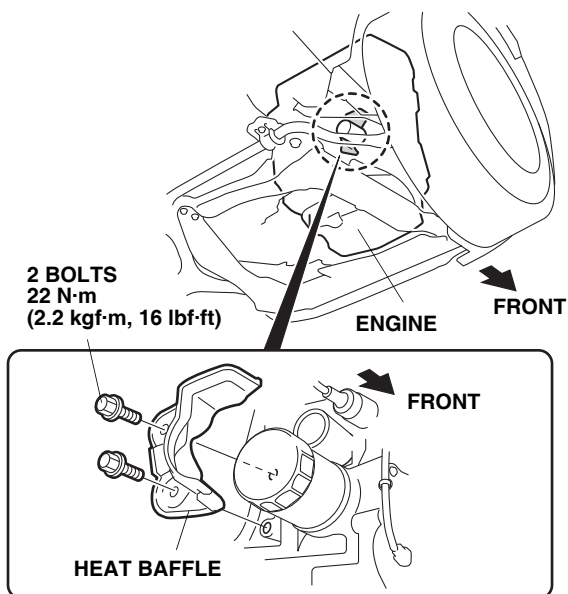

- Remove the two bolts from the underside of the vehicle and remove the heat baffle from the engine.

- Remove the drain plug from the rear of the engine block near the oil filter. Coolant remaining in the engine jackets will flow out of the drain plug hole when removed. Retain the drain plug to be used if the engine block heater is removed.

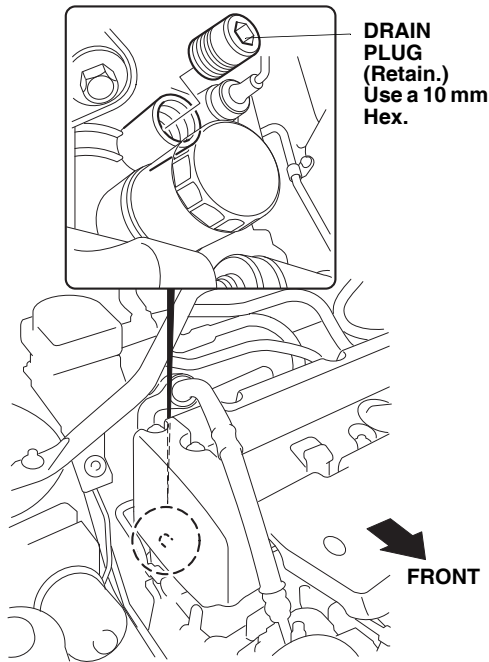

- Install the engine block heater with the aluminum washer into the bolt hole using a 24 mm socket and a torque wrench. Torque the engine block heater to 60 N·m (6 kgf·m, 44 lbf·ft).

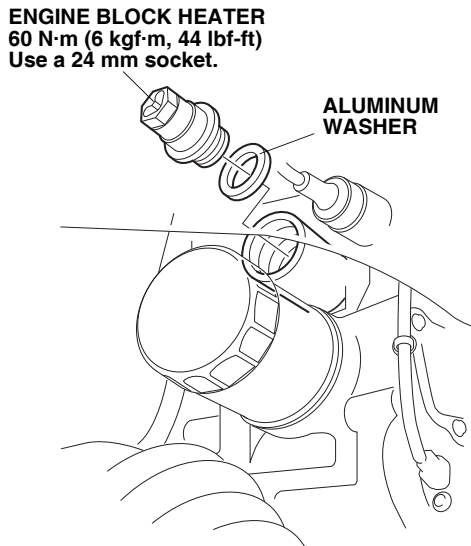

- Using a tape measure, measure the heater harness and mark it at the A, B, and C point shown. Install one wire tie with clip on the heater harness.

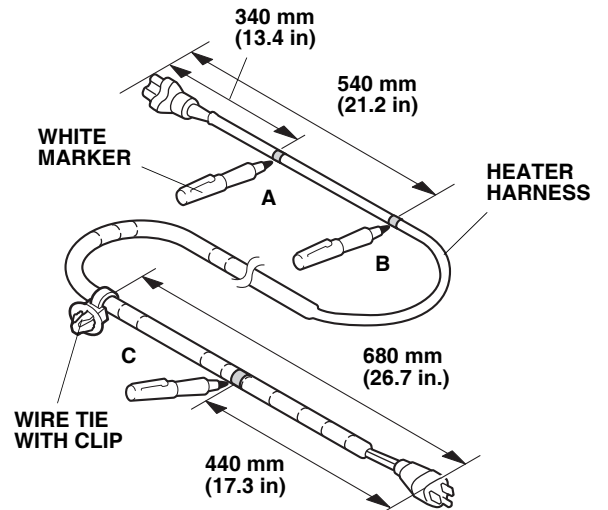

- Plug the connector of the heater harness into the engine block heater, and route the heater harness over the engine. Secure the heater harness to the vehicle harness with one white wire tie in the area shown.

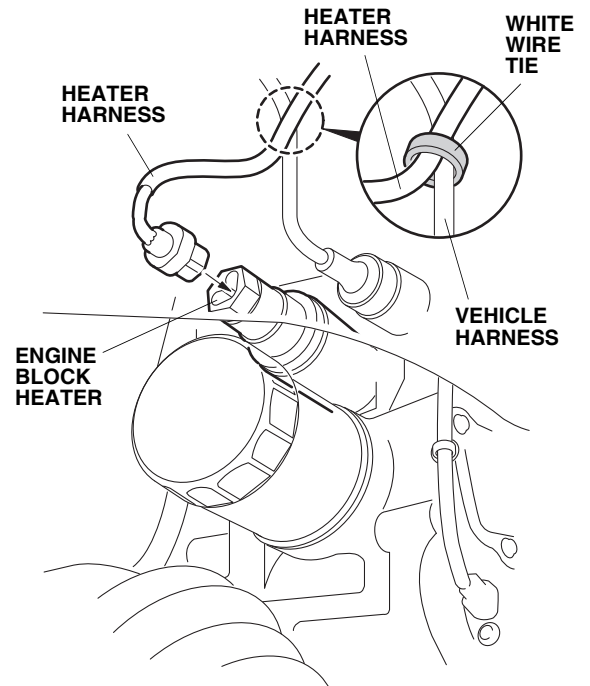

- Reinstall the heat bottle. Lift down the vehicle.

- Route the heater harness alongside the vehicle harness, and secure the heater harness to the sensor connector and the vehicle harness with two black wire ties in the areas shown.

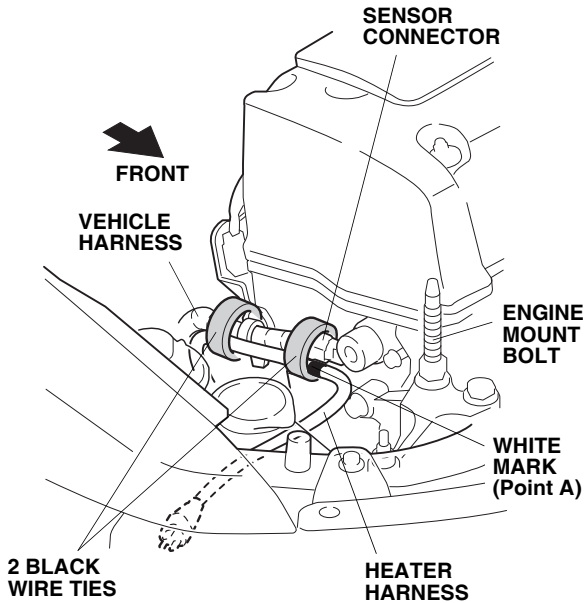

- Continue routing the heater harness under the ABS unit bracket along the vehicle harness, and secure the heater harness to the vehicle harness with two black wire ties in the areas shown.

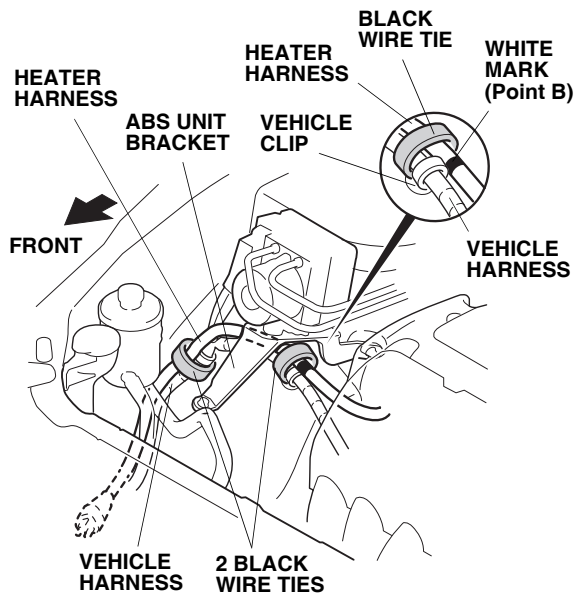

- Route the heater harness as shown, then secure the harness with two black wire ties in the areas shown.

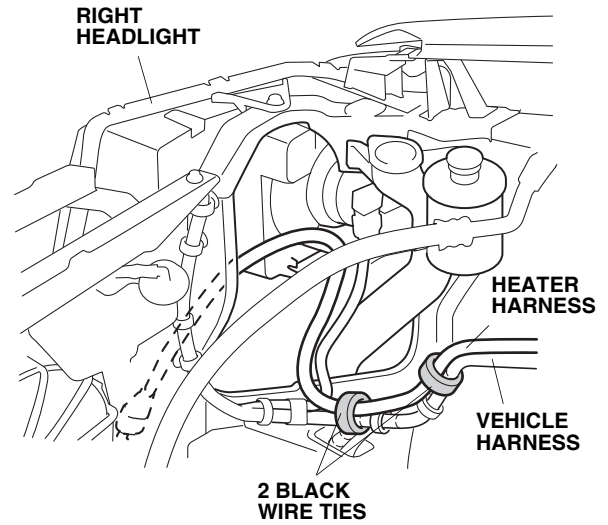

- Route the heater harness as shown. Attach the wire tie with clip to the vehicle panel hole.

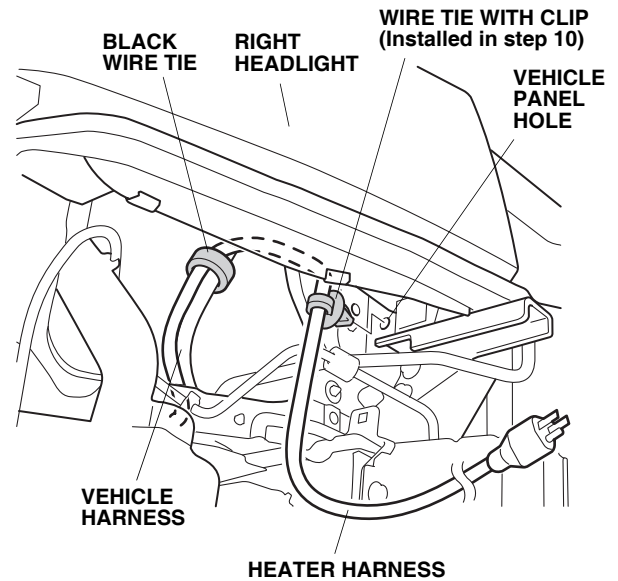

- Using one black wire tie, secure the heater harness to the vehicle harness.

- Secure the heater harness with one white wire tie and two black wire ties through the holes as shown.

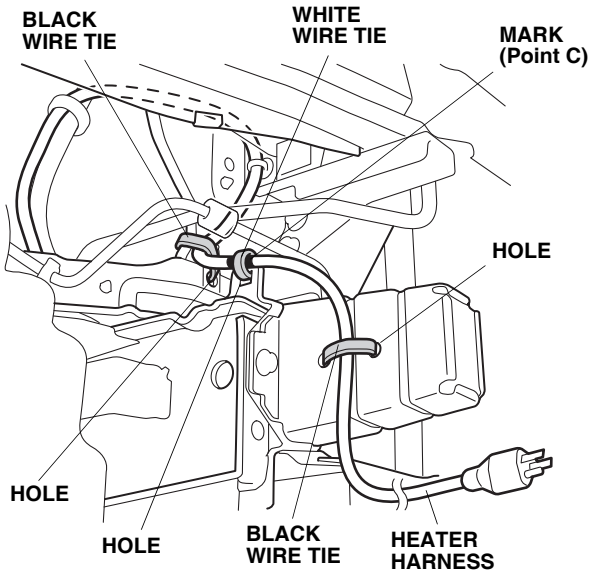

SC Model: Go to step 22.

LX, EX, EX-P Model

- Route the heater harness as shown. Reinstall the front bumper in the original position.

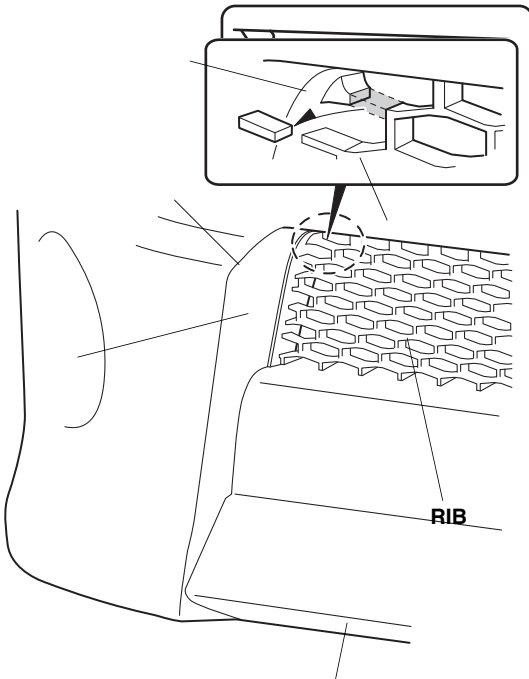

- Attach the protective cap to the bumper rib, then plug the heater harness connector into the cap.
- Secure the heater harness to the rib with one black wire tie as shown. Go to step 26.

## SC Model

- Cut off the rib as shown. Trim the lower grille if necessary.

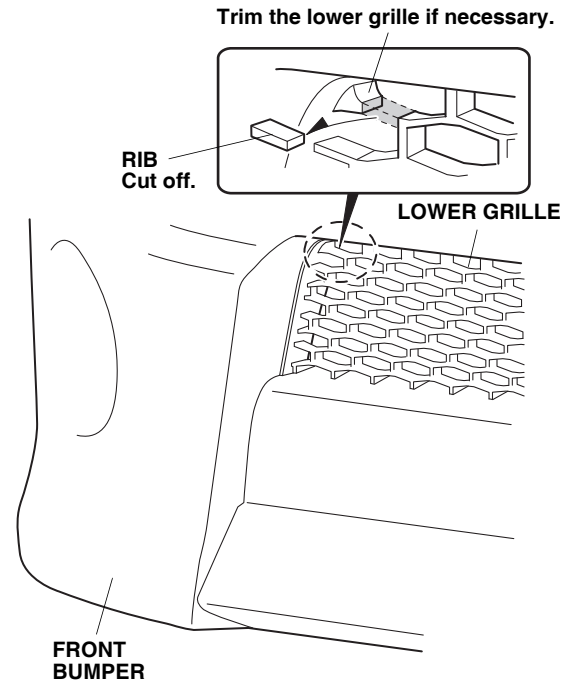

23. Route the heater harness as shown. Reinstall the front bumper in the original position.

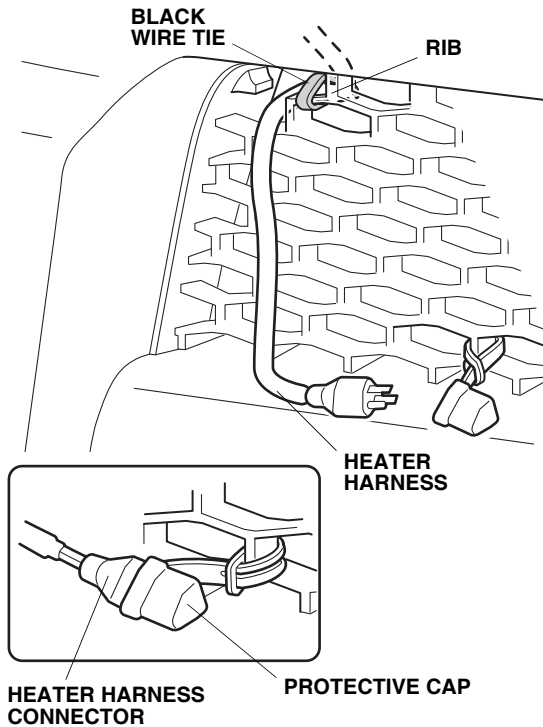

24. Attach the protective cap to the rib, then plug heater harness connector into the cap.
25. Secure the heater harness to the rib with one black wire tie as shown.

26. Reinstall all removed parts except for the radiator cap.
27. Check that the heater harness is routed properly and all connectors are plugged in.
28. Reconnect the negative cable to the battery.
29. Reinstall the radiator drain plug.
30. Fill the system with the recommended coolant. Follow the instructions described in the Service Manual to fill and bleed the cooling system.
31. Check the coolant reservoir for the correct level and check the cooling system for the signs of leakage. Repair as necessary.
32. Reinstall the radiator cap to the radiator.
33. Put the drain plug (removed in step 8) in the glove box.
34. Enter the radio anti-theft code, and reset the radio station presets.
35. Reset the clock.

NOTE: When the battery is disconnected, the driver's window AUTO function is disabled.

- Start the engine. Push down on the driver's window switch until the window is fully open.
- Pull up on the driver's window switch fully to close the window completely, then hold the switch for 1 second or more.
- Lower and raise the window to check operation of the driver's window AUTO function.